

Models 12-13PC Stump Grinder Operation & Maintenance Manual



**PowerTek Inc.
P.O. Box 3
Lebanon, In. 46052
1-877-769-7835**

3-14-08

TABLE OF CONTENTS

WARNINGS SAFETY.....	2-3
HOW TO USE YOUR STUMP GRINDER.....	4
WORK ZONE.....	5
INITIAL INSPECTION.....	6
TRANSPORTATION & SET-UP.....	6-7
OPERATION.....	7-10
STARTING.....	7
GRINDING STUMPS.....	8
ADJUSTABLE HANDLE FREIGHT.....	8
DIRECTIONAL CONTROL.....	9
STOPPING.....	10
MAINTENANCE.....	9-11
ENGINE.....	9
FUEL.....	9
BELTS.....	9
CUTTER BELT REPLACEMENT.....	9
SHARPENING CUTTERS.....	10
REPLACING CUTTERS.....	11
TOOTH GAUGE.....	11
CUTTER WHEEL BEARINGS.....	11
MAINTENANCE SCHEDULE.....	12
BRAKE ADJUSTMENT.....	12
EXPLODED VIEW 12/13PC.....	13
PARTS LIST 12/13PC.....	14
WARRANTY INFORMATION.....	15-16



WARNING

WARNING TO PURCHASERS OF INTERNAL COMBUSTION ENGINE EQUIPPED MACHINERY OR DEVICES IN THE STATE OF CALIFORNIA:

The equipment that you have purchased does not have a spark arrester muffler. If this equipment is to be used on any forest or brush covered land or grass covered un-improved land in the State of California, the law requires that a spark arrester muffler be installed and be in effective working order. The spark arrester must be attached to the exhaust system and comply with Section 4442 of the California Public Resource Code.

The engine exhaust from this equipment contains chemicals known to the State of California to cause cancer, birth defects or other reproductive harm.



WARNING

This manual contains vital information for the safe use and efficient operation of this equipment. Carefully read this operation maintenance manual before using this equipment, as failure to adhere to the instructions could result in death, serious bodily injury and/or property damage.

The Stump Grinder is to be used only for grinding tree stumps. Using this machinery for any other purpose may cause injury and or property damage. Improper use of the grinder will void the warranty.

1. ***Read the entire owner's manual carefully before operating the stump grinder. Also, read the entire Engine Operator's Handbook.*** Familiarize yourself with the, proper use of the Stump Grinder. Know the controls and how to stop quickly.
2. Do not allow children to operate the stump grinder. Do not allow adults to operate the stump grinder without proper instruction. Do not allow anyone to operate the stump grinder who is not acquainted with the Safety Instructions.
3. Be especially watchful of children and pets darting into the operating area and/or danger zone.
4. Wear protective clothing-long pants and heavy work boots as well as ear and eye protection while operating the Stump Grinder.
5. Keep your mind and eyes on the machine while operating it. Do not let others distract you.
6. Check the stump grinder for any loose parts before operating.
7. *Never* place hands or feet anywhere near the cutter blade. The blade is larger than it appears when it is operating.
8. Make sure you are aware of the location of any pipes (water, gas, electrical, etc.) above or below the ground.
9. Clear the work area of all foreign objects such as sticks, stones, wires, etc.
10. Never operate the unit without the safety guards in place and operating properly. Keep equipment in good working condition.
11. Take all possible precautions when leaving unit unattended. Stop engine and remove ignition key to prevent unauthorized use.
12. When refueling machine: shut off engine, do not smoke or allow any hot or burning material near.
13. Before removing or replacing teeth or belts, or before performing any maintenance: shut off engine and wait for all moving parts to stop, disconnect spark plug wire' and remove key.
14. **Stability:** The stump grinder has a narrow wheelbase and can become unstable under adverse conditions. Always go straight up or down on steep hills. Avoid steep side angles. When grinding, avoid dropping one wheel into a hole to avoid a side tip of the unit.
15. When stump grinder is being transported on a trailer or in a truck, make sure the machine is securely fastened to prevent property damage.

BEFORE YOU CUT:

Before you start to grind the stump, remove all debris-dirt, rocks, metal, and loose wood from around the area of the stump before the first cut. Be sure to remove any debris that may also be embedded in the tree stump itself. Debris can wear or damage the cutting teeth and can be a safety hazard. If the teeth meet these foreign objects, the stump cutter can propel these objects great distances.

Before you start the machine, become familiar with all of the controls on the stump grinder. Locate the key switch, throttle, choke, presence handle, and brakes. Check to see if the debris curtains and guarding are in place to help reduce flying objects. Take time to read all the decals and warnings that are on the machine. Read the operation and maintenance manual, it will give you information that can save you time as well as prevent serious injury.

Make sure the teeth on the cutter wheel are in good shape. Inspect them for sharpness, freedom from nicks, and damage. Teeth can wear down quickly causing performance problems as well as lost productivity.

When you are finished, lift the cutter wheel from the stump before shutting the engine off.

OPERATION:

The type of wood will determine how much to cut at one time. Softer woods such as pines or firs are easier to remove than harder woods such as elm, oak, ash or maple. For harder wood, take shallow cuts. Cutting harder woods will dull teeth faster, therefore, be prepared by having an extra set of teeth available.

If the stump is on a hill, level the area where the stump grinder will be setting. If grinding is attempted without leveling, the stump grinder could tip over.

Do not take large cuts. The recommendation is to take 1/2-inch deep cuts and then sweep side to side. Cuts deeper will not only slow productivity but could cause damage to the machine as well as personnel injury. Also, start at the front of the stump and work toward the center. If the stump is very large, it may be necessary to work from more than one side.

When grinding you may go as low as 10 inches below ground level. Make sure to clear away all dirt, rocks, and debris before you continue to grind.

SAFETY TIPS:

The stump grinder is a powerful machine and can throw debris. Be prepared by wearing protective clothing such as gloves, ear protection, eye protection, long pants, and heavy boots. Never leave the operating position while the machine is engaged in a stump.

Make sure there is no one near the machine while it is in use. Use signs and/or barricades to restrict pedestrian traffic around the danger zone. Keep all children away from the stump grinder and the work area.

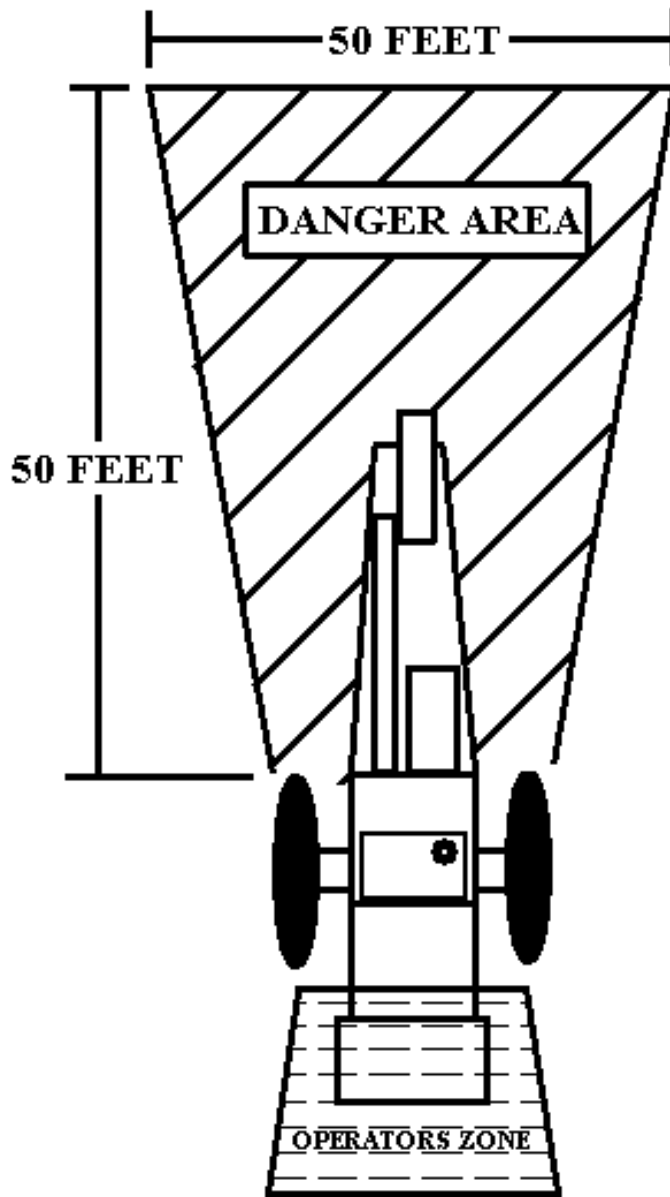

WARNING

When operating grinder do not allow anyone to be in the danger zone while stump grinder is running or serious injury or death may occur.

INSPECTION

Upon receiving your stump grinder, inspect and report any shipping damage to the carrier immediately. PowerTek is not responsible for damage during transportation.

TIRES

Inflation pressure may change with temperature and or altitude. Check and adjust tire pressure to the tire manufacturer's recommended tire pressure as marked on the tire of the stump grinder.

ENGINE

The stump grinder engine was shipped from PowerTek with the proper amount of oil. However, you should double-check the level and add to or change the oil if conditions warrant. (see Engine Operators Handbook for full details).

PRE-USE INSPECTION

Check for any loose bolts or parts before starting or first use.

PREPARATION:

Unit should not be operated until the owner's manual is read, all safety decals are noted and the user has complete knowledge of all controls.

TRANSPORTATION

It is the responsibility of the owner and/or operator to be aware of and abide by all applicable state and local regulations regarding transport of equipment and trailers (i.e. lights, tags, registration, etc.). Pick-up truck or similar vehicle may be used to transport the machine. The stump grinder may also be transported on any suitable trailer. Make sure it is properly secured.

SET-UP

The following procedures should be performed before each use of the stump grinder.

Check the unit for any loose parts. Tighten nuts and bolts and make sure all safety guards and devices (Belt Guard, Brakes, Kill Switch and Clutch Switch) are securely in place and working. Please check all cutters to make sure they are tight.

Check the cutters for dulling. It is important to keep cutters sharpened by grinding or replacing them. Dull cutters will cause excessive engine wear and poor performance. See the Maintenance Instructions for details.

Check the oil and fuel level in the engine. Follow the Engine Operators Handbook if fluid needs to be added or changed.

Check the air filter. The air filter should be cleaned of dust regularly. See the Engine Operators Handbook for details.

Check the tension of the engine belts. The cutter wheel belts should have a deflection at the center of 3/8", under 5-lbs. deflection. Recheck belt tension after every use.

STARTING (Fig. 2 & 3)

1. Turn the ignition switch to on position.
2. Slide the choke to close.
3. Raise cutter wheel off the ground.
4. Depress the operator presence control bar and pull the rope to start the engine.
5. Keep the control bar depressed and slide the choke open.

Important Note: The control bar is designed as a safety feature. The engine will not start or operate without depressing the presence control bar.

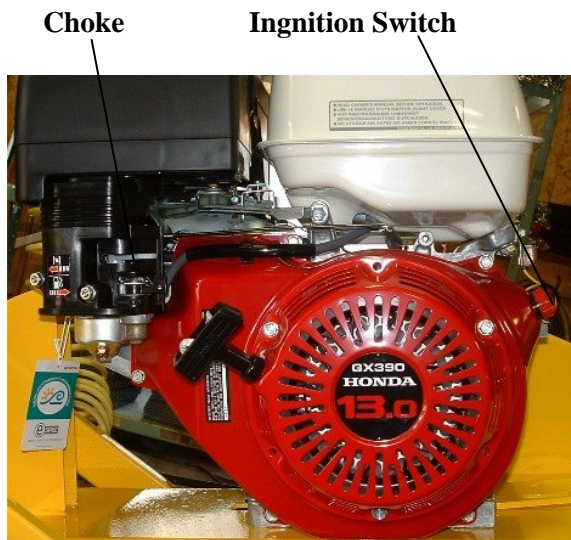

(Fig. 2)



(Fig. 3)

GRINDING STUMPS

1. Start the engine according to instructions. Keep cutter wheel elevated.
2. Use the throttle to gradually bring the RPM's up to full speed.
3. To move the stump grinder, keep cutter wheel elevated and push forward.
4. Position the cutter wheel over the front edge of the stump and set (one) brake. The grinder will pivot on the locked wheel. Position this wheel nearer the center of the stump. You may need to adjust the handle position for better leverage depending on the height of the stump.
5. Slowly lower the stump grinder until the wheel comes in contact with the stump. Move the stump grinder back and forth in a long slow sweeping motion. Maintain the same elevation until a section has been removed, then lower stump grinder to take out the next section and continue until the front part of the stump is removed.
6. When the front part of the stump has been removed, release the brake and move the grinder forward to the new edge, and reset the brake. Releasing one brake and locking the other will sometimes help to move forward a short distance?
7. Repeat Steps 6 and 7 until the stump is completely removed. Do not exceed 10" below ground level or 10" above the ground.

ADJUSTABLE HANDLE HEIGHT

The handle can be raised or lowered to provide different leverages to better handle different stump heights. (Maximum stump height 10" above ground. Maximum below ground cut is 10")

**CAUTION**

Shut off engine and wait for all moving parts to stop before adjusting handle.

TO ADJUST THE HEIGHT:

Holding the handle firmly, pull the handle lock pin to unlock the handle. Raise or lower the handle as needed and let the lock pin slip back into one of the holes in the bracket.

ENGINE

Follow the instructions in the Engine Operators Manual for all maintenance of the engine such as checking the oil, cleaning air filters, etc.

FUEL

Use standard unleaded gasoline in the stump grinder engine.

BELTS

Check the condition and tension of the drive belts before each operation. When properly tensioned, the belts should give a 3/8" deflection at the center span under approx. 5 lbs. of pressure.

CUTTER BELT REPLACEMENT

If the belts are excessively worn or can no longer be properly tensioned, they must be replaced. Use a A65 size belt when replacing the belt. To remove cutter belt, lightly loosen the tensioner bolt and the pivot bolt on the backside of the belt cover in front of the engine. Place tensioner wrench between the two tension bolts. Push the wrench handle toward from the cutter wheel. Remove belt. Replace with new belt. Pull wrench handle away cutter wheel until proper tension of 3/8" at 5 lbs. is attained. Hold wrench as you tighten the tensioner bolt and pivot bolt. Replace belt cover. See fig. 6 & 7.

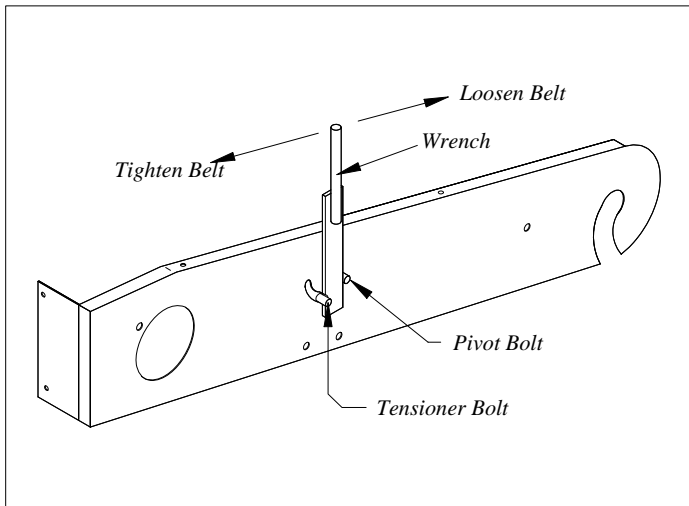

(Fig. 6)

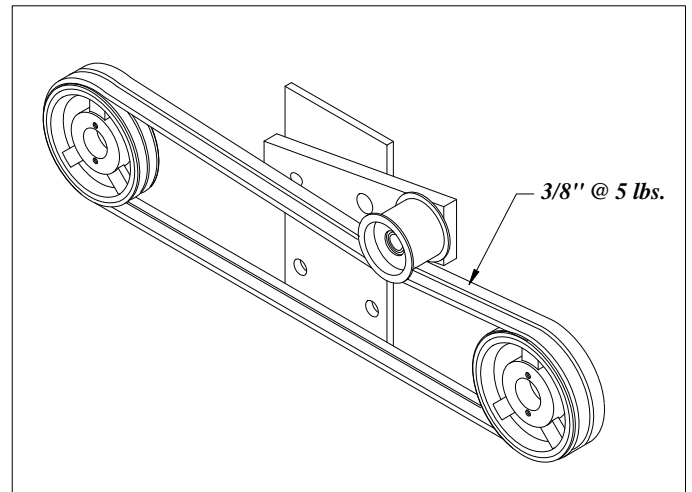

(Fig. 7)

SHARPENING CUTTERS

The cutters should be sharpened frequently for higher performance and a longer life. It is also easier to grind them if they are ground often.

*You will need a carbide-grinding wheel (green wheel) to sharpen them. Use a coarse grinding wheel to grind the steel shank. Be sure to maintain the back grind of 15 degrees (approximately). The cutters must be replaced when the tooth has been sharpened so that 1/4" (approximately) of the carbide is left.

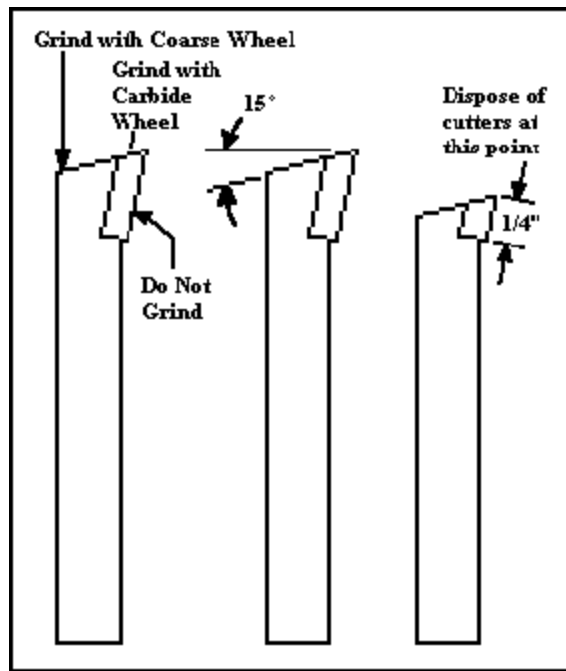

(Fig. 8)

TOOTH SELECTION

WHEN ORDERING TEETH USE THIS GUIDE TO ORDER SINGLE TEETH.

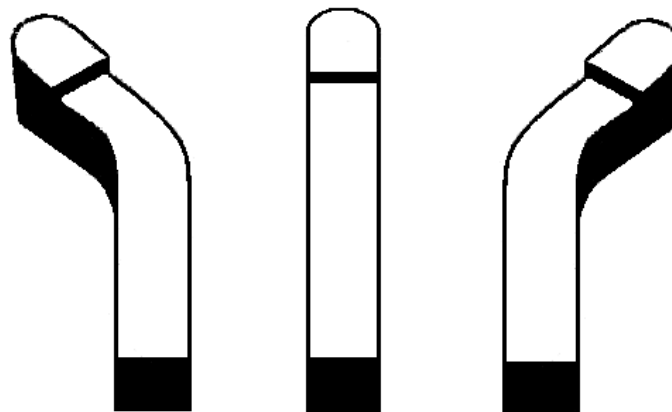

16265 (L.H.)

16263 (ST.)

16264 (R.H.)

REPLACING CUTTERS (Fig. 9)

Remember before you replace any cutters you must turn the engine off, wait for moving parts to stop, remove the key from the ignition and remove wires from spark plugs.

1. Put the handle in the transport position and tilt the Stump Grinder all the way back until it rests firmly on the ground.
2. To make cutter replacement easier, you can slide tensioner wrench handle through the hole in the cutter guard and cutter wheel. This will prevent the wheel from turning during blade replacement.
3. Remove the allen head bolts (16262) from each of the cutter pockets and remove the cutters.
4. Install the new cutters in pairs alternating the cutters as shown, keep carbide side down.
5. Tighten the allen head bolts only tight enough to hold the cutters in the pockets, make sure all of the cutters are extended past the cutter wheel equally. **(Fig. 10)**
6. Torque each allen head bolt to 105 ft. lbs. (alternating as you tighten) to lock the cutters in the pockets.
7. Once you have installed all of the cutters, double check to make sure all the allen head bolts have been tightened securely and make sure all the cutters are equally extended. **NOTE:** cutter wheel viewed from bottom of stumper. **(Fig. 9)**

Important Note: Do not operate the Stumper if any of the cutters are missing. This will cause the cutter wheel to be out of balance. Also, make sure all of the pockets are the same kind.

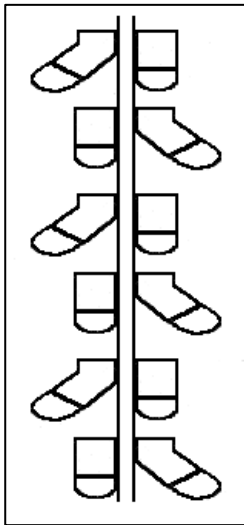

(Fig. 9)

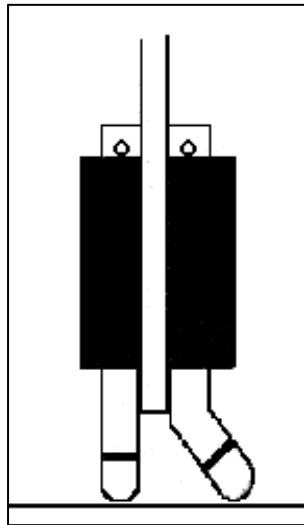

(Fig. 10)

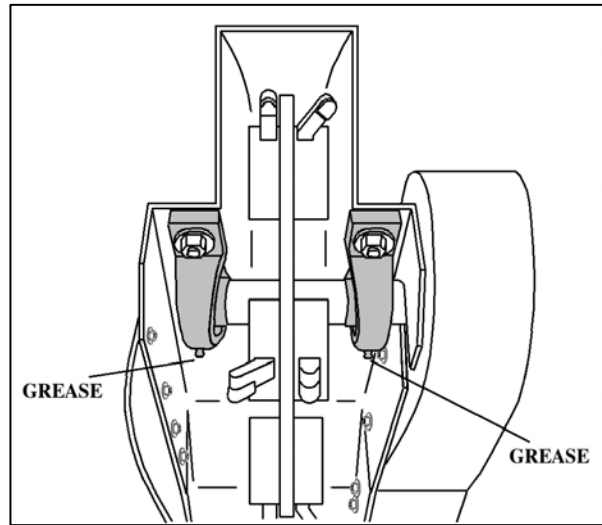

(Fig. 11)

CUTTER WHEEL BEARINGS (Fig. 11)

Grease -cutter wheel bearing every 40 hours of operation **NOTE: DO NOT OVERGREASE.**

MAINTENANCE SCHEDULE				
	Daily	Weekly	Monthly	Yearly/as Required
Check engine oil			X	
Check Machine Tire Pressure	X			
Inspect/Check Engine Cooling Fins	X			
Check for Loose Bolts	X			
Check Stump Grinder Teeth	X			
Check Air Cleaner	X			
Grease Bearings			X	
Check Belts for Proper Tension		X		
Check Brake Adjustment		X		
Check Rubber Guards			X	
Check and Gap Spark Plugs				X
Change Engine Oil as Indicated in Engine Manufacturers Owners Manual				

Brake Adjustment

There are three (3) places where brakes cables can be adjusted. Please follow in this order and test operation before proceeding to the next adjustment if needed. (Fig 1)

1. Ball Joint:

Remove the nut holding the ball joint to the brake assembly lever. Thread the ball joint in to tighten. Re-fasten the ball joint to the lever.

2. Brake Assembly Adjustment Screw:

In order to reach the brake assembly adjustment screw, it is necessary to remove the hubcap and cotter key. Disconnect ball joint and slide the wheel and caliper out. Loosen locknut and tighten cap screw to remove most of the free play in brake lever. Attach ball joint to cable leaving 1/4" adjustment. Replace the wheel, cotter key and hub cap.

Fig 1

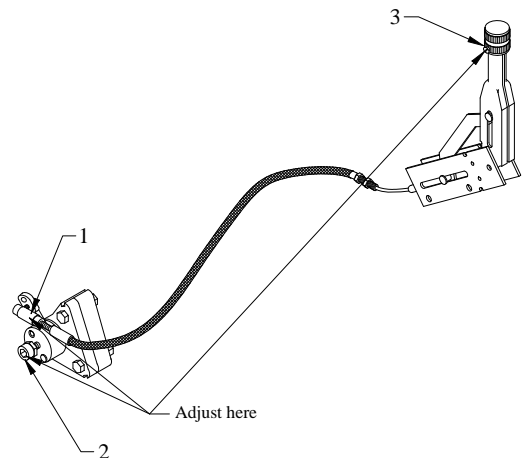

3. Brake Handle:

Loosen set screw on the brake handle knob. The tension is very sensitive and you should use only light pressure and turn in small increments when turning the knob to tighten. After adjustment, re-tighten the set screw.

NOTE: Be sure inner cable is not stopping against cable liner. This will cause the cable to break. (Fig 2)

Fig 2



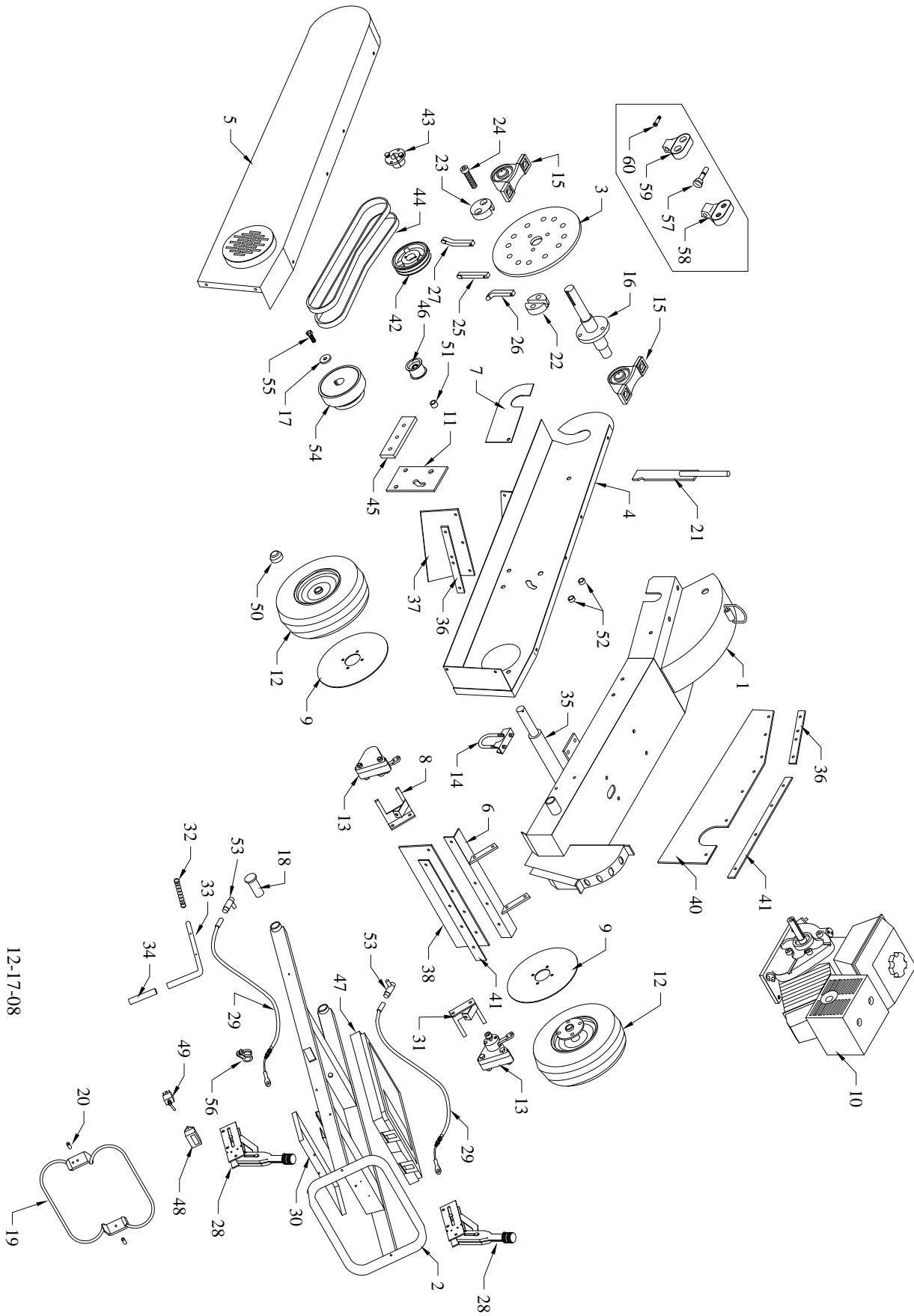

12-17-08

WARRANTY INFORMATION

Each new product is warranted against manufacturing defects in workmanship and/or materials under normal use and service for a period of 12 months from the date of delivery of the product to the original purchaser. PowerTek, Inc.'s obligation under this warranty shall be limited to the replacement to the original purchaser of any part which, as delivered to the original purchaser, and upon PowerTek, Inc.'s examination, is shown to PowerTek, Inc.'s satisfaction, to be defective due to faulty workmanship or materials at the factory.

This warranty does not apply to damage in transit, damage caused by user misuse, negligence, accident, normal wear, or alterations or repairs done outside the factory and/or authorized service stations as determined by PowerTek, Inc. This warranty does not apply to any labor charges in connection with the replacement parts claimed to be defective.

All parts claimed to be defective must be returned to PowerTek, Inc.'s factory for inspection, repair or replacement, with all transportation or mailing charges prepaid. It is the exclusive responsibility of the purchaser to bear the transportation or mailing charges in any warranty claim.

This warranty specifically excludes engines or batteries, which are warranted separately by their respective manufacturers, all claims for defective batteries; engines or engine parts must be made in accordance with the battery and/or engine manufacturers warranty. This warranty also specifically excludes costs of regular maintenance and replacement of service items such as belts, hoses, blades, and similar items.

PowerTek, Inc. reserves the right to make changes upon PowerTek, Inc., products without imposing any obligation upon PowerTek, Inc. to install the same on a product manufactured prior to the change. PowerTek, Inc. makes no other warranties, representations or promises other than those set forth herein. **POWERTEK, INC. SPECIFICALLY DISCLAIMS ANY AND ALL IMPLIED WARRANTIES OF FITNESS FOR PARTICULAR PURPOSE AND MERCHANTABILITY.**

The remedies available to a distributor, dealer, and/or purchaser in connection with PowerTek, Inc.'s warranty set forth above. In no event will PowerTek, Inc. be liable for special, incidental or consequential damages.

POWERTEK, INC. WARRANTY PROCEDURE

- A. All requests for warranty must have approval from PowerTek, Inc. before work starts, or the warranty claim will be denied.
- B. All requests for warranty must be made on an **O.P.E.** warranty claim form. This is available from an authorized distributor or dealer on a no charge basis.
- C. It is the responsibility of the distributor; dealer and/or purchaser to complete the form warranty claim and submit it to PowerTek, Inc.
 1. The form must be filled out completely. It is the sole responsibility of the purchaser to obtain the proper and correct information for the warranty claim. Claims received without serial numbers, model numbers, replacement part numbers, purchase dates, repair dates, purchasers correct address, signature or other information requested by PowerTek, Inc. shall be returned without service.
 2. Warranty claims that are illegible will be returned without service. Please type or print in black ink.
 3. PowerTek, Inc. warranty makes no allowance for the time spent to fill out the warranty claim, any such claim will be denied.

4. All parts shall be retained and tagged for a period of sixty (60) days or until credit is issued.
 5. The factory may request parts to be returned for examination or analysis. These parts shall be sent by prepaid freight to the PowerTek, Inc. Returns sent freight collect, without the express, written permission of PowerTek, Inc. shall not be accepted by PowerTek, Inc.
 6. It is the responsibility of the dealer to review the claim and to comply fully with all procedures set forth herein. Failure to do so shall result in the denial of the warranty claims.
- A. Any warranty payments by PowerTek, Inc. will be -paid by credit memo to the distributor, dealer, rental store or purchaser.
- B. All warranty claims, which are denied, will be returned with a reason for denial.
- C. Labor Allowance.
1. The warranty labor rate is \$40.00 per hour.
 2. The actual time is divided into tenths of an hour. The warranty form should show the time to the nearest tenth of an hour.
 3. Labor credit is based on the actual time required only to make the repair.

Items not covered by warranty.

1. Mileage and transportation costs of any kind. All warranty is "Bench Work" only. The warranty specifically states that any transportation charges in connection with a warranty repair are the exclusive responsibility of the purchaser.
2. Postage, delivery, telephone calls or similar communication.
3. Normal maintenance or adjustments. This includes set up and service.
4. Battery, engines or engine parts. Warranty on batteries, engines, engine parts or other vendor parts that are covered by the component manufacturers warranty and must be handled by that component manufacturers representative.
5. Failure caused by neglect, normal wear, or abuse. PowerTek, Inc. depends on its dealer network to accurately determine when such conditions occur.
6. Any alteration of the original design of the unit, or the use of unauthorized or non-PowerTek, Inc. parts. Any claim submitted containing such unauthorized alteration repairs shall be rejected.
7. Freight or transportation -damage. All such damage is the responsibility of the carrier and any claim for damages must be made with the carrier.
8. Parts or labor supplied by unauthorized repair facility.
9. Compound or repeat warranties caused by negligent/improper repair.
10. Any claim for warranty where the date of repair -exceeds thirty (30) days from the submission of the warranty claim.
11. Any claim for warranty on the entire unit.
12. Warranty claim involving oils or fluids of any kind.
13. Any warranty claims for leaking, punctured, blown, flat, or otherwise damaged tires on units that have been placed in service.
14. Lost time, lost rental, lost profits, or other economic loss due to warranty work.

Voluntary cooperation with the entire warranty procedure will make the program work better for both the purchaser and PowerTek, Inc.