

Model 727

POWERTEK

Model 727/731 Hydraulic Feed Chipper Operation & Maintenance Manual

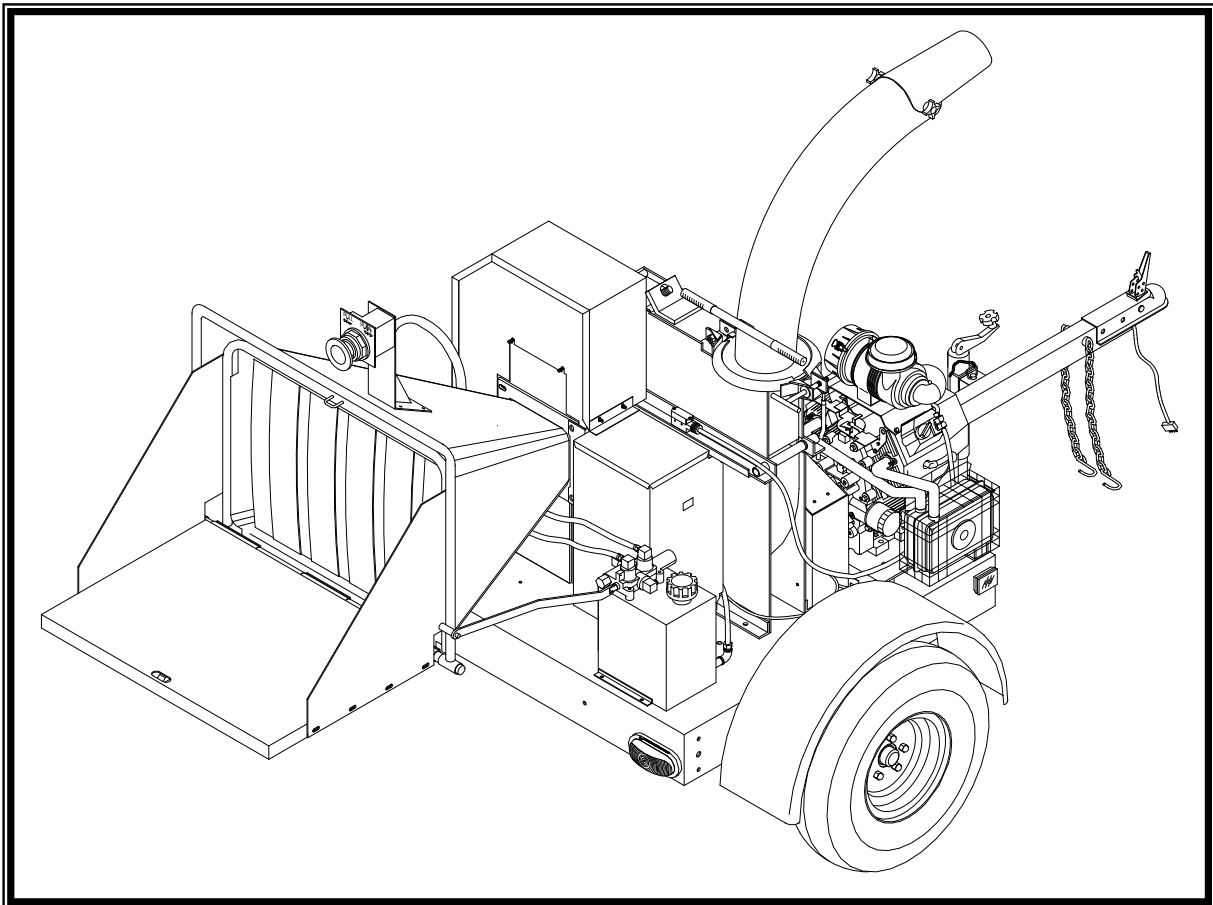

**PowerTek Inc.
P.O. Box 3
Lebanon, IN 46052
1-877-769-7835**

3-26-09

WARNINGS**WARNING****WARNING TO PURCHASERS OF INTERNAL COMBUSTION ENGINE
EQUIPPED MACHINERY OR DEVICES IN THE STATE OF
CALIFORNIA:**

The equipment that you have purchased does not have a spark arrester muffler. If this equipment is to be used on any forest and brush covered land or grass covered un-improved land in the state of California, the law requires that a spark arrester muffler be installed and be in effective working order. The spark arrester must be attached to the exhaust system and comply with Section 4442 of the California Public Resources Code.

The engine exhaust from this equipment contains chemicals known to the State of California to cause cancer, birth defects or other reproductive harm.

WARNING

This manual contains vital information for the safe use and efficient operation of this equipment. Carefully read this Operation Maintenance Manual before using this equipment, as failure to adhere to the instructions could result in death, serious bodily injury and/or property damage.

This wood chipper is to be used only for chipping wood. Using this machine for any other purpose may cause injury and or property damage. Improper use of this chipper will void the warranty.

SAFETY

Warnings.....	1
Table of Contents.....	2

GENERAL OPERATING RULES

General Operating Rules.....	3
Safety Rules	4
Work Zone	5

INITIAL INSPECTION

Engine	6
Tires.....	6
Blades and Anvil	6
Loose Parts	6
Freight Damage Inspection ..	6
Battery.....	6
Belts.....	6

ON SITE SET UP

Jack Stand.....	7
Engine	7
Discharge Chute.....	7

OPERATION

Starting Gas Engine.....	8
Feeding Material.....	8
Cleaning Out Debris.....	8
Stopping.....	8
Emergency Stop Switch.....	8
Starting Hydraulic Feed.....	9

MAINTENANCE

Engine.....	10
Fuel.....	10
Battery.....	10
Ignition.....	10
Cooling	10
Air Cleaners.....	11
Clutch.....	11
Flywheel Bearings.....	11
Wheel Bearings.....	11
Hour Meter.....	11
Discharge Chute.....	11
Drive Belts	12
Chipper Blades	12
Anvil Adjustment.....	13
Maintenance Schedule	14

SPECIFICATIONS

General Specifications.....	14
Performance Specifications ..	14

HYDRAULIC SYSTEM MAINT.

Cleaning Hydro System	15
Hydraulic Oil.....	15
Hydro Motor Shaft.....	15
Hydraulic System Pressure...	15

TROUBLE SHOOTING

Diagnostic Procedures	16
Chipping Systems	17
Electronic Feed Control.....	17
Setting Electronic Board.....	18
Notes	19

ELECTRICAL SCHEMATIC

31 HP Vanguard Schematic...	19
Electrical Schematic.....	20

PARTS LIST

Exploded View (General)	21
Parts List (General).....	22
Exploded View (Hydro).....	23
Parts List (Hydro).....	24

OWNERS INFORMATION

Record Information	25
--------------------------	----

WARRANTY

Warranty Information	26
Warranty Procedure.....	26
Warranty Procedure (Cont.)...	27

PREPARATION RULE

1. Always inspect the chipper before and after each use to ensure safety and optimum performance.
2. Inspect the tires, safety chains, and towing hitch for any malfunctions. Fix or replace any parts if found to be defective.
3. Check that the running lights and turn signals are working properly.
4. Inspect that all decals are legible and in place. Replace any defective decals.
5. Inspect the entire chipper for loose nuts and bolts. Properly tighten if any are found.
6. Check all chamber bolts, blade bolts and anvil bolts. Torque to the specified torque as mentioned later in the manual.
7. Remove and store flywheel safety pin before starting the unit.
8. Grease all required and marked lubrication points.
9. Check all fluid levels in the engine. Fill if required.
10. Check all belts for wear, cracking or misalignment. Replace if required.
11. Check all belts for proper tension. If loose retighten to proper tension.
12. Inspect clutch shoes for wear. Replace if fiber pad is worn from shoe.
13. Inspect knives and make sure they are sharp and properly installed. If there are round edges or nicks that would not allow the blades to operate properly, re-sharpen them. If the blades are cracked or chipped replace them or they could cause serious injury or property damage. Torque all blade bolts to the proper torque.
14. Inspect that all hydraulic hoses are in good working order and are not cracked, worn, or leaking.
15. Check that all safety devices and switches are functioning properly before use.
16. Always shut chipper engine off, allow flywheel to stop turning, disconnect the spark plug wires and remove the key from the engine: before servicing any part of the chipper.
17. Always insert safety pin into the flywheel before replacing or servicing blades and anvils.
18. Read the manual from cover to cover before using chipper.
19. Know the capabilities and limitations of the chipper before using it.
20. **THINK SAFETY!**

TOWING

1. Before towing, inspect the safety latch on the hitch coupler to make sure it is closed, latched, and pinned to prevent premature uncoupling of chipper hitch.
2. Safety chains should be crossed under the tongue of the chipper and hooked securely to the frame of the towing vehicle.
3. Before towing be sure to rotate jack stand into the transport position and make sure it is properly secured.
4. Make sure that the person who will be towing the chipper has been properly instructed about local and state rules of the road and towing procedures.
5. **DO NOT** tow chipper faster than 45 MPH or chipper may tip over when going around corners.

SAFETY RULES**DO'S**

DO make sure that anyone who operates this chipper reads and understands all operating instructions as to its proper use and operation as well as all safety instructions.

DO block the tires of chipper before using. **DO** check engine oil level before starting. **DO** wipe up spilled fuel right away from the engine and chipper before starting.

DO make sure there are no obstructions in the in feed chute before starting the engine.

DO make sure all bolts, nuts and parts are tight before starting.

DO make sure the discharge chute and deflector shield are properly adjusted to dispatch chips in a safe direction, away from pedestrians, animals, homes or other property that could be injured or damaged.

DO keep children and pets away from the work area while you are operating the chipper.

DO take care when chipping dead or frozen wood in order to avoid kickback.

DO make sure that all safety decals are read and understood before operating the chipper.

DO survey work area for any potential dangers for the operators of equipment.

SAFETY GEAR

DO wear appropriate safety clothing. It is crucial to protect the operator from serious injury.

DO wear eye protection (safety glasses or helmet with safety face shield.)

DO wear hearing protection. (Ear plugs or muffs.)

DO wear gloves, heavy work shoes, and protective clothes.

DO NOT'S

DO NOT operate the chipper alone. **DO NOT** allow children to operate the chipper.

DO NOT use your feet or hands to force material into the feed chute. Use a push stick to push smaller or stuck branches into chute.

DO NOT ride or allow anyone else to ride on or in the chipper.

DO NOT override any safety devices that have been factory installed.

DO NOT operate chipper with upper chamber open.

DO NOT attempt to clear any debris from any chute or chamber while the chipper is running. Disconnect spark plug wires and remove the key before any clean out is attempted.

DO NOT smoke or use any type flame or spark near the chipper. Always refuel the engine in an open area and with the engine shut off or the fuel may explode causing serious injury or property damage.

DO NOT use the chipper under the influence of alcohol or drugs or you may cause serious injury to yourself or someone else.

DO NOT for any reason, reach into feed area or chamber while chipper is running or serious injury or death can result.

DO NOT wear loose clothing that may become entangled in brush or machinery or serious injury or death may occur.

DO NOT wear any strings on clothing that may become entangled in brush or machinery or serious injury or death may occur.

DO NOT wear any jewelry that may become entangled in the brush or machinery or serious injury or death may occur.

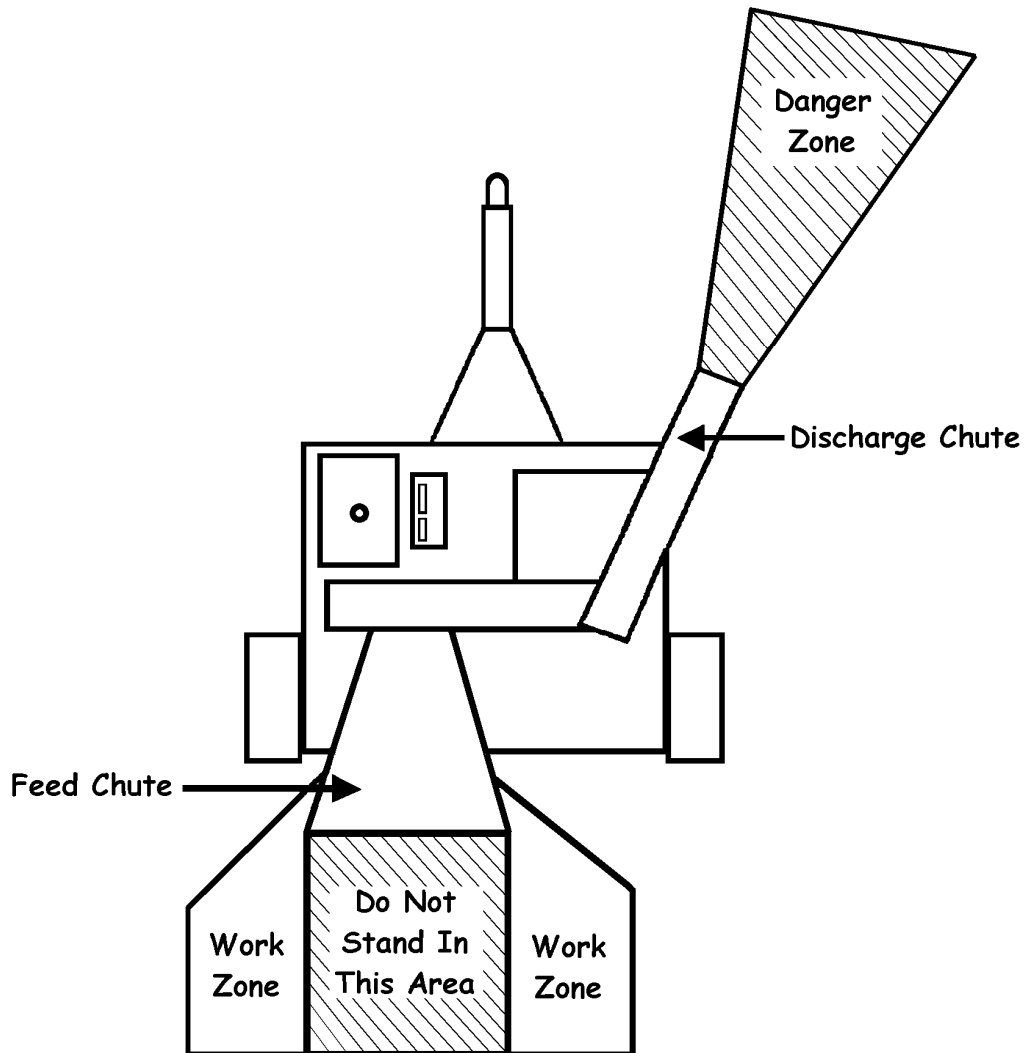

!! WARNING !!

When operating this unit do not allow anyone to be in the danger zone while chipper is running or serious injury may occur.

Important! Upon receiving your chipper inspect and report any shipping damage to the carrier immediately. **POWERTEK** is not responsible for damage received during transport.

ENGINE

The chipper engine was shipped with the proper amount of oil. However, you should check the oil level and add to or change fluids if conditions warrant. (See engine manufacturer's manual for full details.)

TIRES

Inflation pressure may change with temperature and/or altitude. Check and adjust tire pressure to manufacturers recommended pressure when necessary. Maximum tire pressure is printed on sidewall of tire.

DRAWBAR & WIRING

Remove plastic wrap. Lift unit off of skid and block it up. Unpack the drawbar and discharge chute. Slide the drawbar into front opening and bolt it on using hardware already attached to unit. Plug in wiring as illustrated in (Fig. 2)

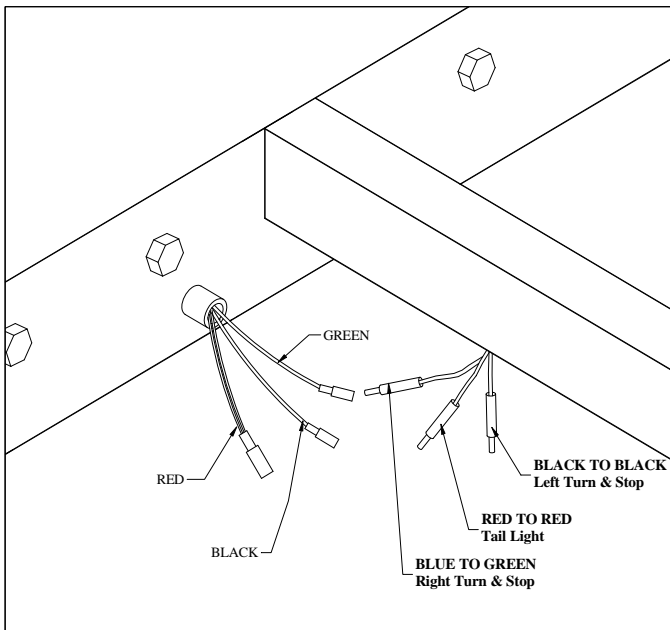

LOOSE PARTS

Check to make sure all nuts and bolts are tight and all safety guards are securely in place.

FREIGHT DAMAGE INSPECTION

Upon receiving your chipper, inspect and report any shipping damage to the carrier immediately.

BATTERY & IN-LINE FUZE

For your convenience the battery is shipped fully energized. However, as a safety precaution the in-line fuze has been disconnected. After removing the unit from its pallet, remove the tape holding the 30A fuze into one side of the fuze holder and reconnect. (See Fig. 1)

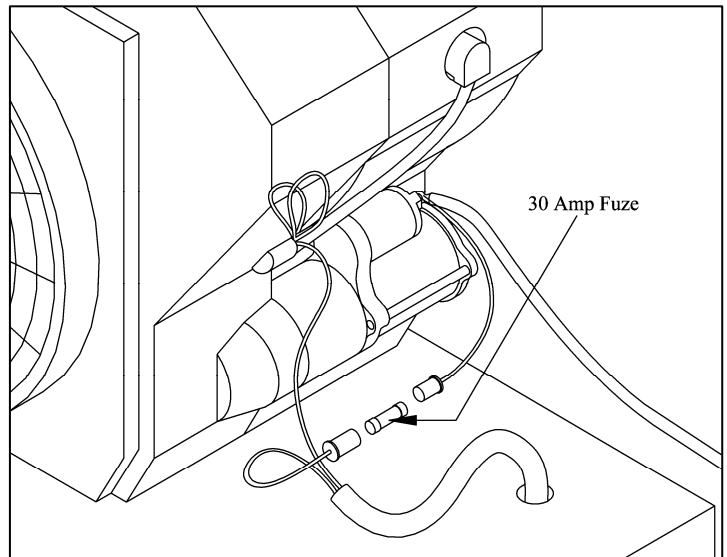

(Fig 1)

(Fig 2)

JACK STAND

Once at your destination the chipper can be uncoupled from or left attached to the towing vehicle. In either case, the weight should be transferred from the vehicle by lowering the jack stand. The wheels should be blocked front & back as a safety precaution or machine may move causing damage to property or bodily harm. (See Fig. 2)

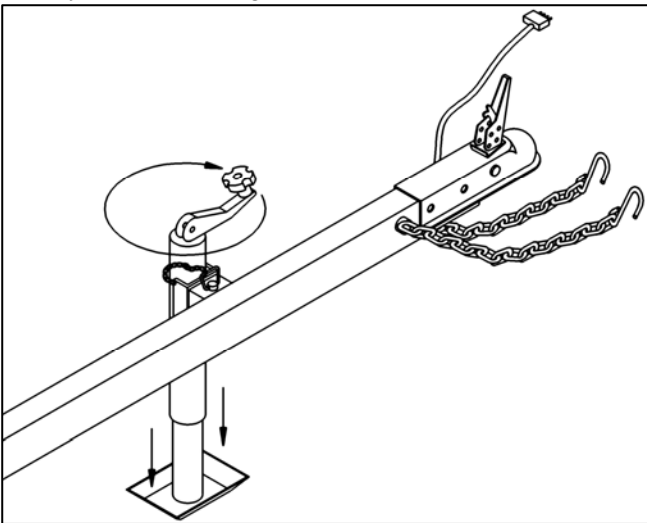

(Fig. 2)

ENGINE

Check the level of engine crankcase oil. If necessary, add oil following the instructions in the maintenance section of engine manual.

Check air filters for excessive dirt and oil and clean as required following the instructions in the maintenance section of engine manual.

DISCHARGE CHUTE

Loosen the discharge chute clamp and rotate the chute to the desired position. Then tighten the chute clamp to lock it into place. (See Fig. 3)

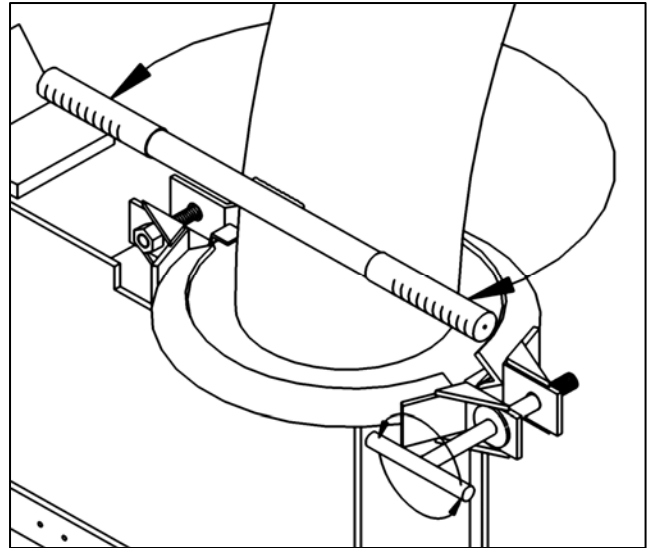

(Fig. 3)

!! CAUTION: !!

Make sure discharge chute is directed away from pedestrians, homes, or other potential safety hazards or injury or property damage may occur.

STARTING GAS ENGINE

Set the throttle to idle speed. If the engine is cold set the choke, then turn the key to “START” position. If the engine does not start within 10 seconds allow a 60 second cool down period between attempts. When the engine starts let the key return to “RUN” position.

Allow the engine to warm up at an idle speed, for 30 seconds then open the throttle. As the centrifugal clutch engages the flywheel will gradually come up to speed, the process should take 30-35 seconds. Run the engine at full RPMs.

Important! If engine is allowed to idle for long periods, clutch damage will occur.

FEEDING MATERIAL

When feeding material into the hopper avoid pieces larger than 7” in diameter or limbs that are not easily handled. Stand to either side of the intake and feed limbs and branches large end first.

If brush tends to hang in hopper alternate with small branches and limbs, **do not** attempt to push brush into the cutter by hand.

If the flywheel speed slows, stop feeding until unit regains momentum. If speed is not regained shut the unit down by putting feed bar in neutral and turning key to the off position and inspect for clogging in the chute and flywheel chambers as described in following section. Also check the automatic feed control system to see if it is operating properly.

CLEARING OUT DEBRIS

!! WARNING !!

Always shut down the unit and wait for all moving parts to fully stop before clearing or adjusting the discharge chute, flywheel or feedbox. Remove key from engine before clearing machine and remove wires from spark plug.

To clear the discharge chute: Remove the chute clamp, take the chute off, and clear out any debris.

To clear the flywheel housing: First rotate the chute around until it is pointing away from the chipper and is parallel to the flywheel. Then remove the lock nut from the housing with a 1 1/16” box wrench and tilt the chute back slowly. (See Fig. 4) Check the housing and clear out any debris.

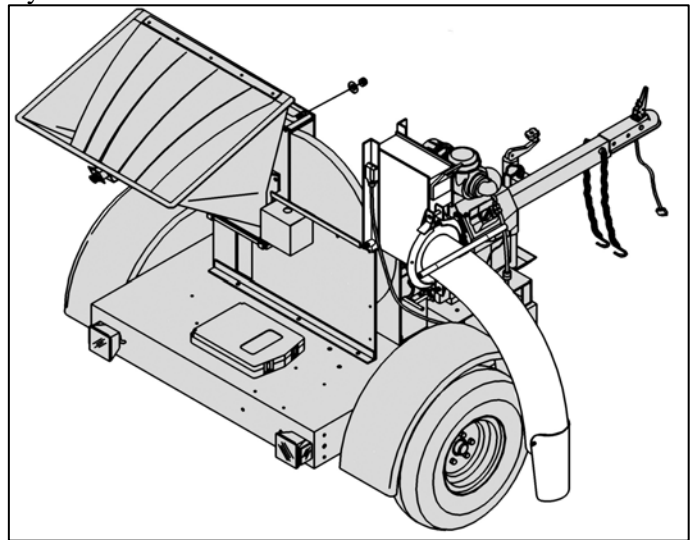

(Fig. 4)

STOPPING

Always allow the chipper to run at full speed for a few minutes before shutting down to clear chips so machine is clean for next use. Do not leave any chips in chipper because they may cause a hazard on the next start up.

Turn key to the “off” position while at full throttle. An electronic fuel shut off will automatically stop fuel from entering engine. Allow flywheel to stop turning before working on the chipper. As a safety precaution always remove the key before working on the machine or leaving it unattended.

EMERGENCY STOP SWITCH

An emergency stop switch is supplied with this unit. The red safety button is located at the top of the feed hopper. Push the button to shut the chipper down. When button is pushed the engine and feed roller will stop. The engine will not restart until button is reset.

STARTING HYDRAULIC FEED

When chipping always run the engine at full throttle. Auto feed will not work at a lower RPM.

When the control bar is in the upright position it is in neutral and the feed rollers should not be turning.

To engage the feed roller, pull the bar towards you. Now you may start feeding brush into the hopper. To reverse the feed roller, push the control bar away from you. (See Fig. 5)

The hydraulic feed system will not work unless engine is running 3100 rpm.

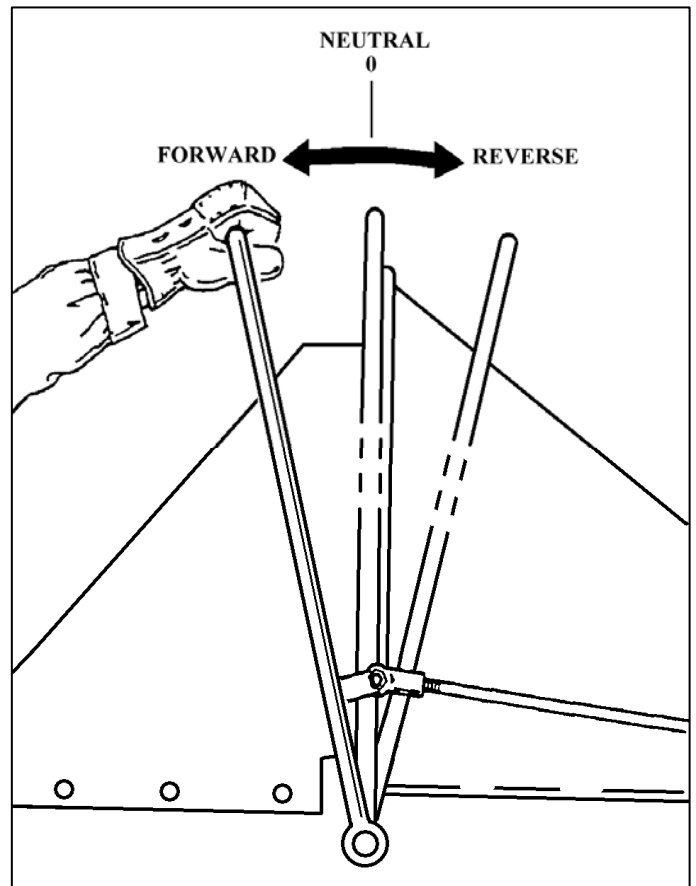

WARNING

Do not attempt to perform any maintenance procedures while engine or any other parts are in motion or while keys are in the ignition. Always remove wires from spark plugs or serious injury may occur.

ENGINE

Check engine crankcase oil before each start. Make sure unit is filled with proper type and quantity of oil. Refer to engine manufacturers manual. Use high-quality detergent oil of API service class SF. Viscosity should be the same as oil currently in engine.

To check oil, park unit on a level surface and allow oil time to drain into sump. Wipe dirt and debris from around fill cap and tube. Remove the dipstick and wipe clean. Return the dipstick fully into the tube. Pull it out again and check the fluid level registering on the stick. If necessary add oil to keep it in the engine's operating range.

In a new engine oil should be replaced after the first 5 hours of operation. For subsequent changes see engine manual.

For best results drain oil when engine is warm. Remove the oil drain plug and dipstick. Allow oil to drain into a clean resealable container to facilitate recycling. Reinstall drain plug and fill to the "F" mark with the appropriate type of oil. See manufacturer's specifications. Discard oil according to local codes

FUEL

For best results, use regular grade unleaded gasoline with octane rating of 87 or higher. When refueling do not overfill the tank, leave room for expansion. Due to its extreme flammability never add gasoline to a hot or running engine.

BATTERY

Each week or every 25 hours of operation check the electrolyte level of each battery cell. If a cell is low add distilled water to bring it up to the level indicator.

If battery is sealed disregard this instruction. When replacing or recharging the battery use extreme care to avoid shorting between positive and negative terminals. To reduce risk of accidental shorting, disconnect the negative cable first when removing and reconnect it last when installing.

IGNITION

The gas engine is equipped with a electronic ignition system which requires very little maintenance. However, every 100 hours of operation the spark plug should be removed for inspection.

Before removing, clean the area around the plug to prevent dirt and debris from falling into the cylinder. Remove and check for fouling, cracked porcelain, or incorrect electrode gap. If necessary replace the plug with manufacturer recommended plug and gap as needed.

COOLING

To prevent overheating and excessive wear, cooling fins should be cleaned every 25 hours or sooner if plugged. Fins can be cleaned by removing cooling shrouds and scraping away dirt and matted material. It is important to reinstall shrouds to insure proper airflow.

AIR CLEANERS

Combustion air is supplied to the engine via a high-density air cleaner element and its surrounding precleaner. To ensure a sufficient air supply to the carburetor, remove and rinse the precleaner every 25 hours of operation. Check engine manual.

Every 25 operating hours inspect the paper element while cleaning the prefilter. Gently tap the flat side of the paper element to dislodge surface dirt. If unit is excessively dirty, bent, or damaged replace element. Re-install both paper filters and secure.

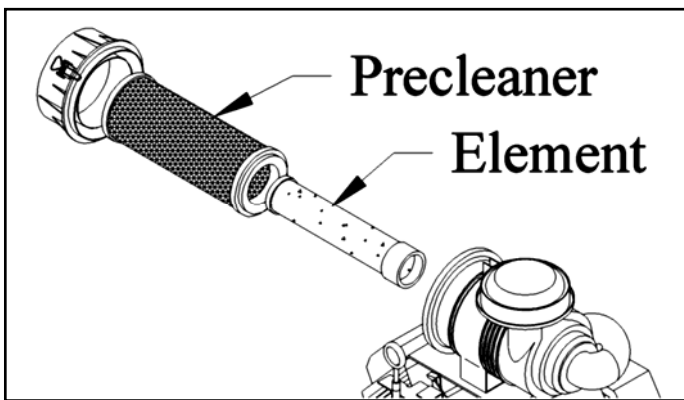

(Fig. 6)

WHEEL BEARINGS

To prevent wheel bearings from burning out or locking up during transport, check and repack wheel bearings every 3 months.

HOUR METER

The meter is fully automatic with a display that may be read at all times, whether the engine is on or off. During running times, engine RPM is shown; after shut down, accumulated running time is shown. After 25 hours of running time, the meter will automatically blink as a signal for oil change. It will continue to blink for a (2) hour period of accumulated running time (ie., 25 to 27 hours). The next alert will automatically appear in 25 hours. No re-set is required.

DISCHARGE CHUTE

If the discharge chute becomes difficult to rotate, grease at the fitting on the underside of the chute base do not over grease or chute will collect dirt. (Fig. 7)

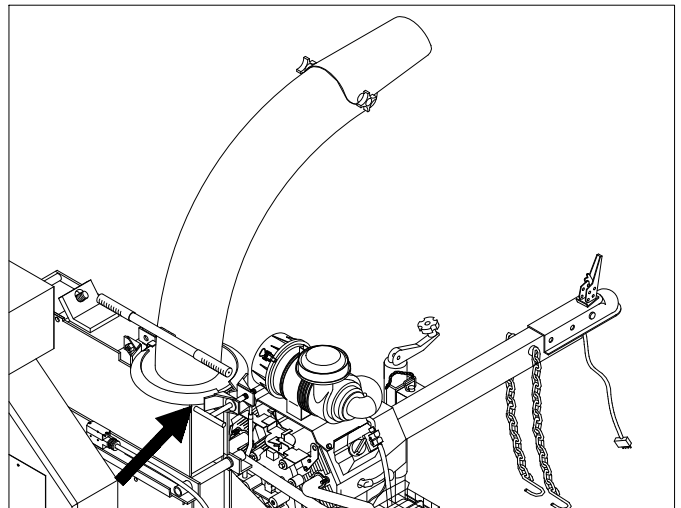

(Fig. 7)

FLYWHEEL BEARINGS

To prevent excessive friction and wear, grease flywheel-bearing blocks on each side of the flywheel every 5 hours of operation. Do not over grease or bearings will collect dirt and wear out prematurely (Fig. 8).

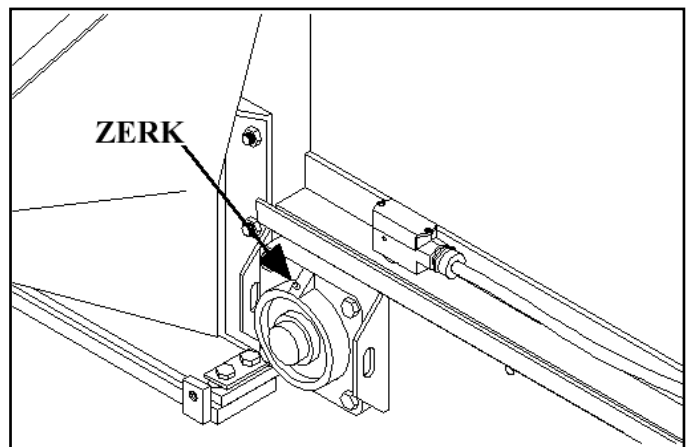

(Fig. 8)

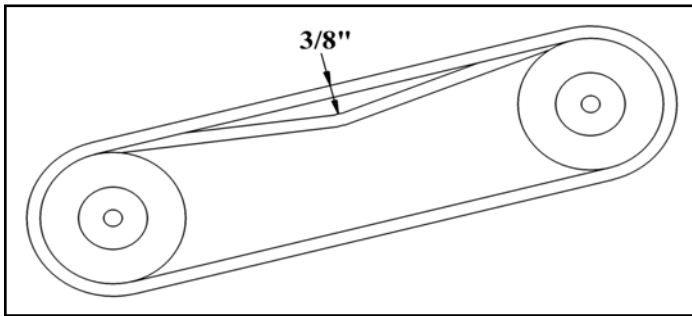

(Fig. 9)

DRIVE BELTS

The flywheel is driven by belts directly from the clutch. The belt must be kept properly tensioned. When properly tensioned, the belts should give a 3/8" deflection under fifteen lbs. of pressure (approx.) at the center span. To adjust belt tension, loosen the four engine sled bolts. Loosen lock nuts on the two tension bolts and adjust the bolts equally to keep the clutch and flywheel pulleys aligned. When the correct tension is achieved secure the lock nuts and mounting bolts. If the belts are excessively worn or can no longer be adjusted to the proper tension they must be replaced. It is extremely important to replace belts in matched sets to ensure uniform power transfer between engine and the flywheel. To replace belts follow the belt tensioning procedure. As stated below.

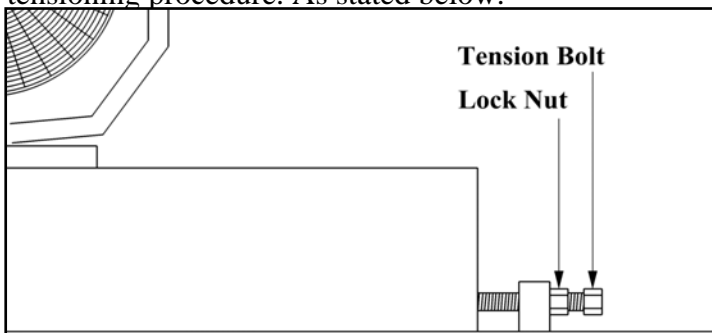

(Fig. 10)

After loosening tension bolts lock nuts, unscrew bolts and slide engine towards the flywheel until belts can be removed. Install new belts then finish tensioning procedure.

CHIPPER BLADES

For optimum cutting potential chipper blades must be kept sharp. To inspect the blades open the flywheel housing using the procedures for clearing the housing. Rotate the flywheel around by hand and check the blades for dulling. If the blades need sharpening or replacing use the following procedures:

1. Insert safety pin to keep flywheel from rotating
2. Remove cutter blades by using a 3/4" box wrench on the lock nuts and a 3/4" socket on the bolt and turn simultaneously.

Note: Anytime you remove blades, check hardware for wear and damage. Replace if needed. When a new set of blades is installed, replace the old hardware with new hardware kit part number 72506A.

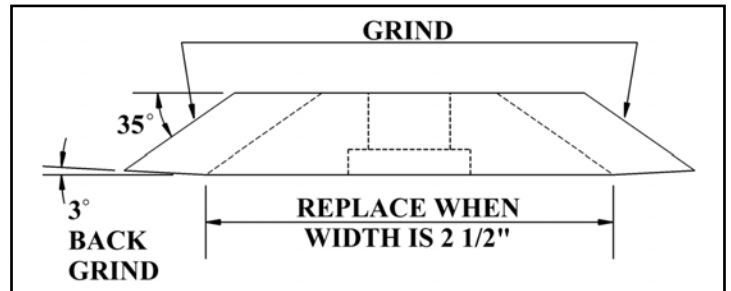

(Fig 11)

- 3a. If blades need rotating:
 - Blades may be rotated so that the other edges of the knife may be used. To rotate, simply turn the blade and reinstall.
- 3b. If blades need sharpening: it is important to maintain the original angle of 35° and the backgrind angle of 3°. Remove equal amounts of material from each blade to avoid vibrations caused by an unbalanced flywheel (blades should weigh within 1/10 oz. of each other).
- 3c. If blades need replacing:
 - Replace blades when they become damaged or repeated sharpening has reduced their width to 2 1/2". Simply remove the old blades and replace with new ones.
4. Once you have reinstalled the blades make sure the jam nuts are tightened to 50 ft. lbs. of torque and the lock nut to 105 ft. lbs. Then adjust the clearance between the anvil and blades using the procedures in the Anvil Adjustment section.

ANVIL ADJUSTMENT

IMPORTANT! You must adjust the clearance between the anvil and blades every time you sharpen or replace the blades. At this time you must also re-torque all anvil bolts to the proper torque setting of 120-ft.lbs.

Steps in anvil adjustment:

1. Remove the 3/4" nylock nut from the upper chamber, and rotate the upper chamber open.
2. Loosen the anvil adjustment bolts and all four of the anvil hold down bolts.
3. Lock flywheel using the locking pin provided with unit.
4. Remove and sharpen or replace blades as required. Re-torque all blade bolts to 135-ft. lbs.
5. Remove the locking pin. Rotate the flywheel so that the flat of the blade is parallel with the Anvil edge at the inside edge of the blade.
6. Slide the gauge, located under engine sled as shown below, into the opening of the upper housing and or through the anvil slot in the side of the chamber. Position the gauge between the blade and anvil.
7. Push the Anvil up against the gauge and tighten down the anvil mounting bolt. Set anvil-blade gap at no less than .075" and no more than .125". The optimum gap is .100". The anvil gauge supplied with the chipper is .094".
8. Rotate the flywheel to see if the opposite blades gap is less than .075" or more than .100". If so repeat steps 6 & 7 for gapping this side as well.
9. Rotate the flywheel so that the blade is parallel with the anvil on the outside edge of the blade. Repeat steps 6 thru 8 for outer edge of blade.
10. Double check anvil-blade gap so that the gap is more than .075" but less than .125".
Remove gauge. Rotate flywheel to make sure everything is assembled correctly.
11. Torque anvil hold down bolts to 135-ft. lbs. each.
12. Tighten the anvil adjusting bolt lock nuts.
13. Close the upper chamber and tighten the 3/4" nylock nut.

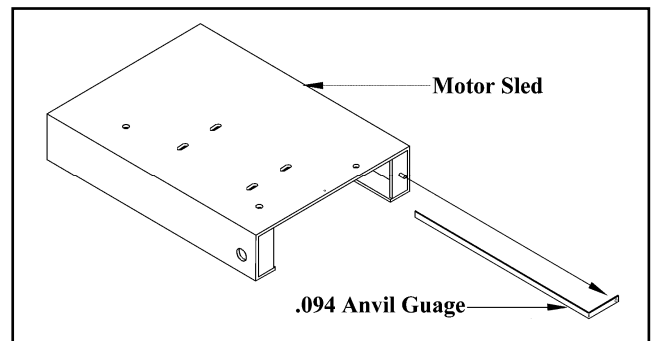
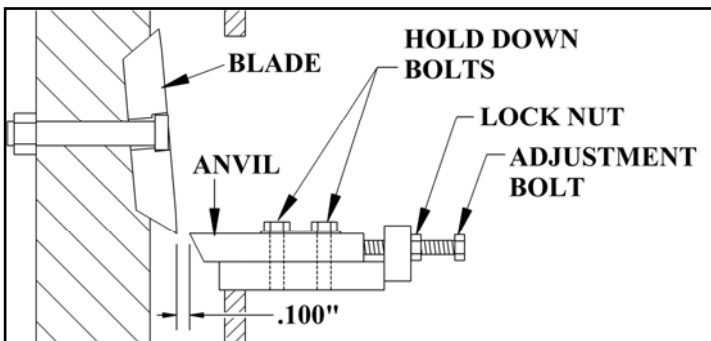

WARNING

THIS PROCEDURE MUST BE FOLLOWED TO ENSURE THE WOOD DOES NOT GET WRAPPED AROUND THE FLYWHEEL AND JAM THE MACHINE AND CAUSE SERIOUS INJURY OR DAMAGE TO PROPERTY

MAINTENANCE SCHEDULE

POWERTEK

	MAINTENANCE SCHEDULE			
	DAILY	WEEKLY	MONTHLY	YEARLY OR AS REQUIRED
Check engine oil	X			
Check machine tire pressure	X			
Inspect/Check engine cooling fins or radiator	X			
Check for loose hydraulic fittings or hoses	X			
Check for loose bolts and nuts	X			
Check hitch and safety chains	X			
Check blades and anvil for sharpness	X			
Check hydraulic fluid level	X			
Check tail lights and turn signals	X			
Check anvil and blade gap (.100)	X			
Check that guards are in place	X			
Check Air Cleaner		X		
Grease bearings		X		
Check belts for proper tension		X		
Check clutch shoes for wear		X		
Check rubber guards		X		
Grease discharge chute		X		
Grease hydraulic motor shaft			X	
Check hydraulic filter				X
Check and gap spark plugs				X

SPECIFICATIONS

GENERAL

Length.....120"
 Width.....68"
 Height.....76"
 Weight.....1680 lb.
 Input Feed.....Hydraulic
 Hopper Opening.....31 1/2" x 23 3/8"
 In-Feed Angle to flywheel.....90°
 Feed Throat.....9" x 7"
 Blade Bolt Torque.....135 ft. lbs.
 Engine.....25 hp elect. start, ovhd valve
 Fuel Tank Capacity.....8 gal.

Clutch.....centrifugal
 Tires.....205/75R14
 Suspension.....Rubber Torsion
 Hitch.....(class 2) 2" Ball-3500 lb. cap.
 Hub.....5 Lug
 Tail Lights.....Standard
 Flywheel.....30" Dia, 1 1/2" Thick (312 lb.)
 Knives.....Two 10" Reversible
 Anvil.....1/2" x 3 7/16" x 12 1/2"
 Anvil Bolt Torque.....120-ft.lbs.

PERFORMANCE

Cutting Capacity.....7" Dia.
 Discharge Distance.....Up to 20 ft.

CLEANING HYDRAULIC SYSTEM

Keep the system clean. The hydraulic pump will last longer with few repairs if the system is kept clean. Keep the oil clean. Debris and dirt in the oil can clog the relief valves and other parts resulting in poor pump performance. Replace the hydraulic oil filter after the first 100 hours of operation and then every 200 hours of operation thereafter. The canister is replaceable.

HYDRAULIC OIL

Do not operate the chipper if the hydraulic oil level is too low. This will cause the pump to overheat. Use a hydraulic oil equivalent to Dextron III ATF. Oil level is 1" from top of reservoir.

HYDRAULIC MOTOR SHAFT

The spline on the end of the hydraulic motor shaft needs to be greased about every 100 hours of operation. Remove the motor and apply 3-4 squirts from a grease gun inside the shaft then replace the motor.

HYDRAULIC SYSTEM PRESSURE

The hydraulic system on the Model 727 Chipper turns at approximately 50 PSI, at this pressure the feed roller should be turning at 50 RPM when turning in the "feed" position. A suitable inline T-fitting and pressure gauge put inline between the control valve elbow and the pressure line to the feed roller motor is where pressure should be tested (fig. 13).

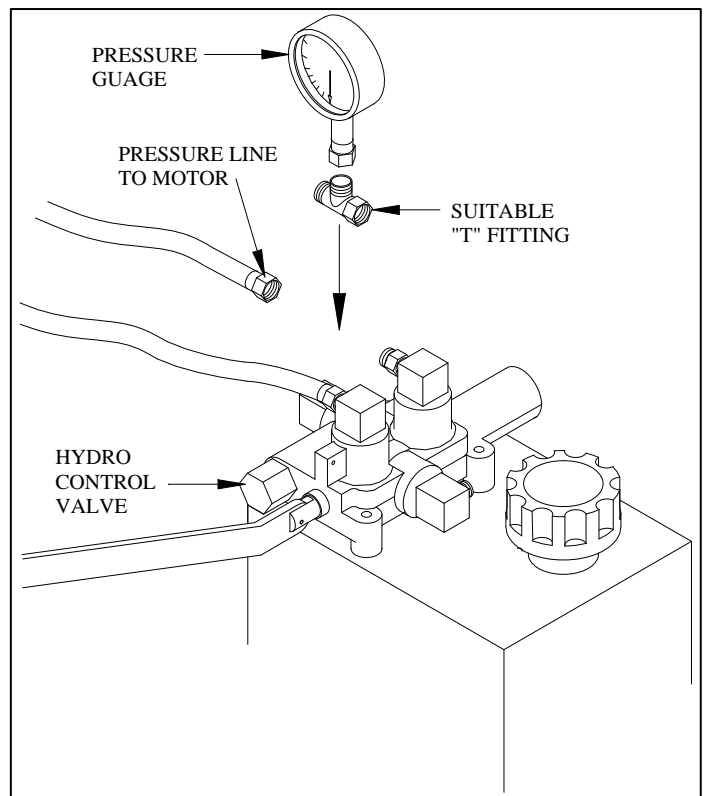

(Fig. 13)

DIAGNOSTIC PROCEDURES

Trouble shooting procedures are provided in the chart below. To use these procedures, first locate the problem description that best describes the trouble that you have encountered. Check the possible causes one at a time. Correct any problems that are found and operate the brush chipper again to verify that you have eliminated the problem.

CAUTION

SHUT OFF THE ENGINE, WAIT UNTIL ALL MOVING PARTS HAVE COMPLETELY STOPPED, AND REMOVE KEY FROM THE IGNITION BEFORE TROUBLE SHOOTING OR PERFORMING MAINTENANCE.

PROBLEM	CAUSE	SOLUTION
Feed roller turns at normal speed but does not feed brush properly.	<ol style="list-style-type: none"> 1. Low oil level 2. Worn pump 3. Worn feed teeth 4. Low pressure setting 	<ol style="list-style-type: none"> A. Add hydraulic oil B. Replace pump C. Grind teeth to sharpen or replace D. Check pressure setting
Feed roller turns at normal speed but slows down or stops when brush is fed.	<ol style="list-style-type: none"> 1. Pump coupling worn 2. Relief valve worn or dirty 3. Worn pump 4. Worn hydraulic motor 	<ol style="list-style-type: none"> A. Replace coupling. B. Clean valve or replace C. Replace pump D. Replace motor
Hydraulic temperature is very hot and slows the system down	<ol style="list-style-type: none"> 1. Worn pump 2. Relief valve stuck open or opens too easily 3. Worn or damaged hose 4. Clogged oil filter 5. Worn hydraulic motor 	<ol style="list-style-type: none"> A. Replace pump B. Clean, readjust or replace relief valve C. Replace hose D. Replace filter E. Replace motor

Note: If help is needed to perform repairs contact PowerTek customer service.

CHIPPING SYSTEM

PROBLEM	CAUSE	SOLUTION
Chipper feeds poorly or chips unevenly	<ol style="list-style-type: none"> 2. Dull blades 3. Anvil is misaligned 4. Anvil is worn 	<ol style="list-style-type: none"> A. Rotate or sharpen blades B. Check anvil and blade clearance C. Remove and re-grind anvil
Discharge chute plugs	<ol style="list-style-type: none"> 1. Engine speed is low 2. Material bridge in chute 3. Over-Feeding 	<ol style="list-style-type: none"> A. Increase engine RPM B. Remove obstruction C. Mix small and large material
Chipper blade hits anvil	<ol style="list-style-type: none"> 1. Insufficient clearance 2. Worn Bearing 	<ol style="list-style-type: none"> A. Reset blade clearance B. Check Bearings
High bearing temperature	<ol style="list-style-type: none"> 1. Improper lubrication 2. Worn bearings 	<ol style="list-style-type: none"> A. Grease bearing blocks B. Replace bearings

ELECTRONIC FEED CONTROL SYSTEM

PROBLEM	CAUSE	SOLUTION
Feed roller does not turn	<ol style="list-style-type: none"> 1. Feed control handle in neutral 2. Unit is not at full speed 3. Speed control settings incorrect 	<ol style="list-style-type: none"> A. Position handle in feed position B. Increase engine throttle C. Check speed control settings

SETTING PRIORITY VALVE

1. Loosen lock nuts on the flow control valve and sequence valve.
2. Turn both set screws counterclockwise to stops with a #5 allen wrench.
3. Turn set screw on flow control valve 5 turns clockwise.
4. Turn set screw on sequence valve clockwise 2 1/2 turns.
5. Set engine RPM to 2600
6. Put the control handle into the feed position. If roller is not turning, turn set screw on flow control valve clockwise until roller turns.
7. Increase engine speed to 3000 RPM
8. Check roller, if it is not turning to full speed (50 RPM) then turn set screw on sequence valve counterclockwise to achieve 50 RPM.

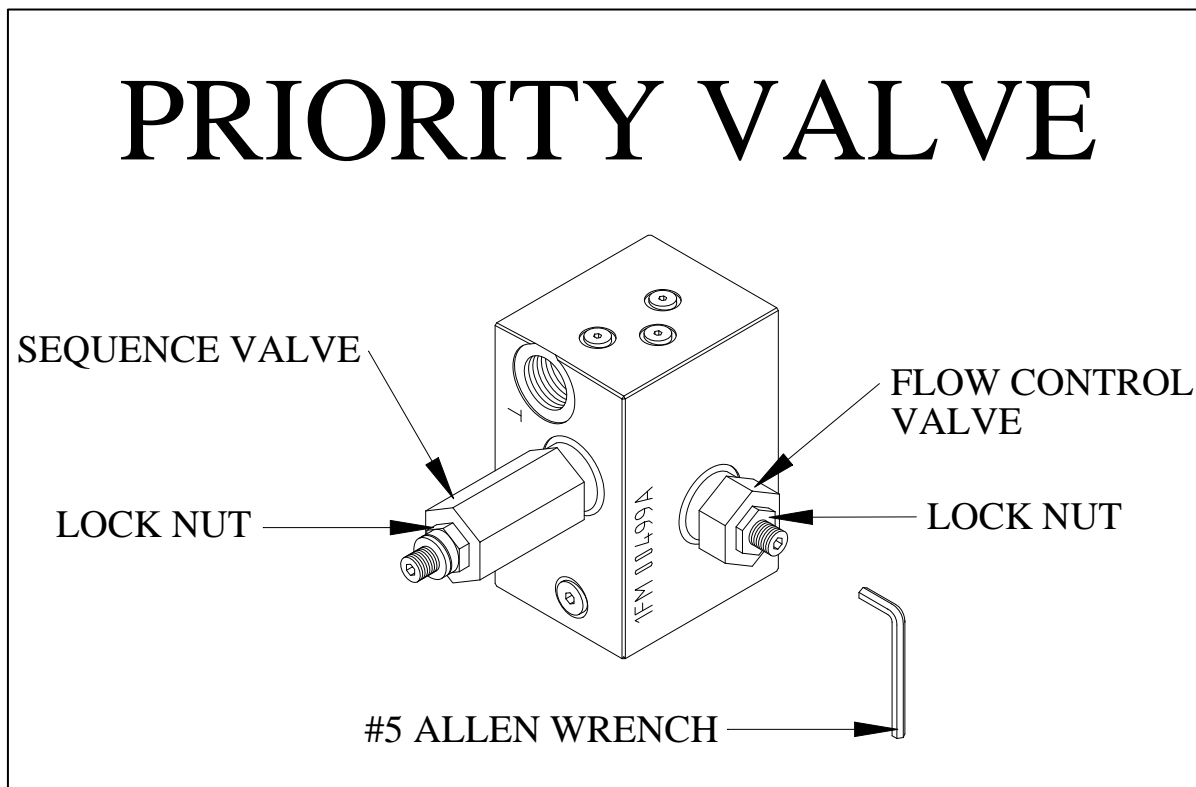

(FIG. 14)

NOTES: _____

ELECTRICAL SCHEMATIC

31 HP Vanguard Schematic, Customer Side

NOTE: COLORS ARE HARNESS WIRE COLORS ON ENGINE SIDE

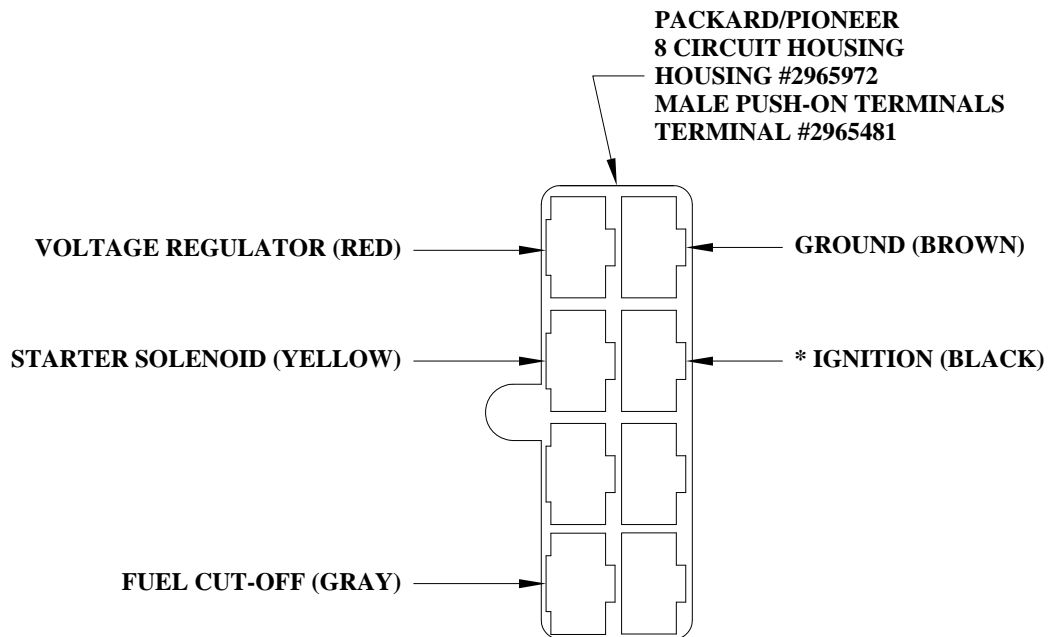

* TO KILL ENGINE CONNECT TO GROUND

PARTS BREAKDOWN (727 GENERAL PARTS)

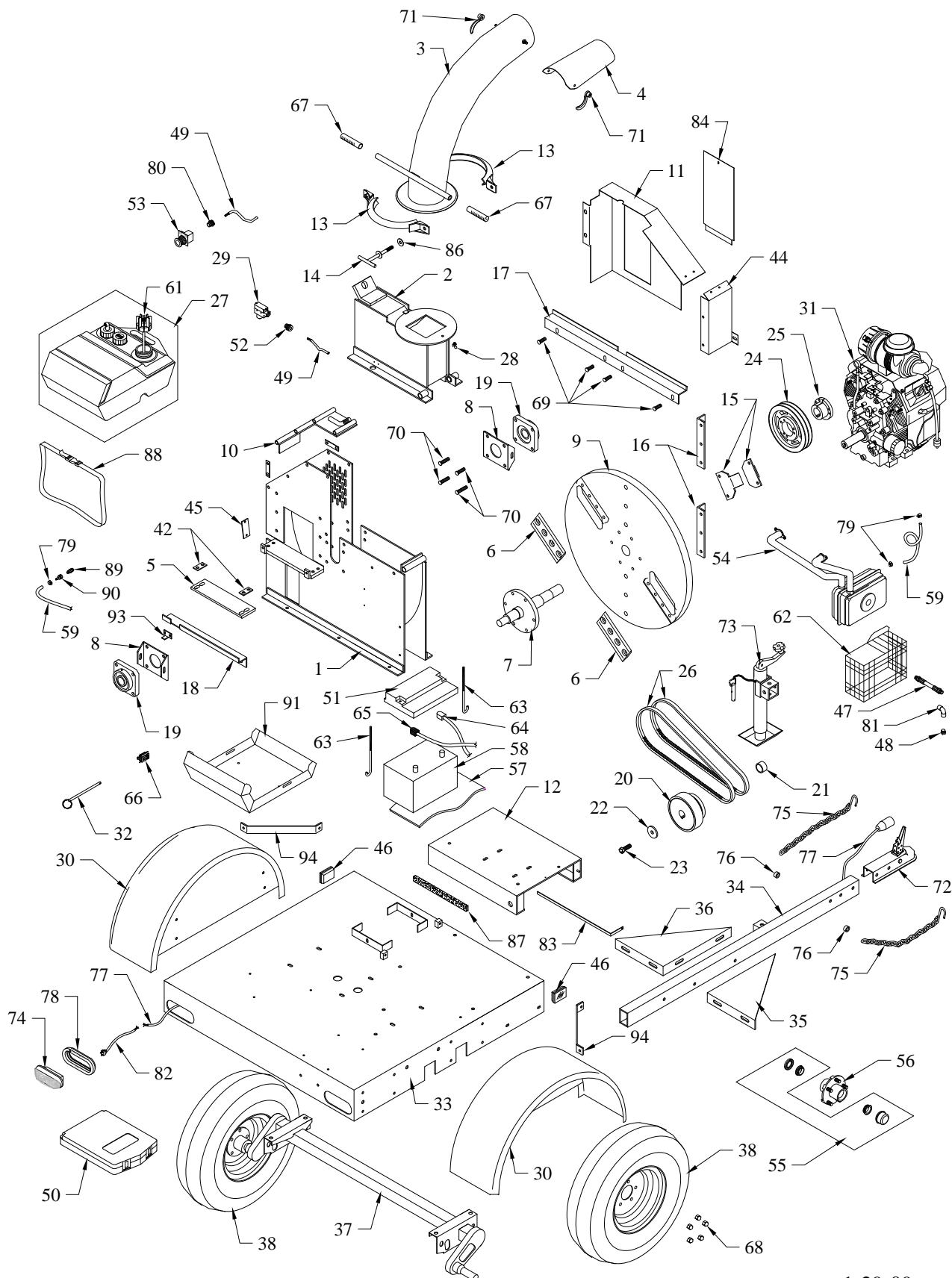

1-29-09

PARTS LIST (727/731 GENERAL PARTS)

POWERTEK

<u>Key</u>	<u>Part No.</u>	<u>Description</u>	<u>Key</u>	<u>Part No.</u>	<u>Description</u>
1	72501	Lower Housing	52	72552	Wire Clamp Nut
2	72502	Upper Housing	53	72552	Stop Switch
3	72503	Discharge Chute	54	72554	Muffler Assembly, Kohler
4	72504	Discharge Chute Deflector	55	72555	Bearing Kit
5	72505	Anvil	56	72556	Hub
6	72506	Chipper Knife	57	72557	Battery Pad
7	72507	Flywheel Hub & Shaft Assembly	58	72558	Battery
8	72508	Bearing Bracket	59	72559	Fuel Line
9	72509	Flywheel	61	72609	Gas Cap thru s/n 62581
10	72510	Removable Casing Assembly		16216	Gas Cap s/n 62582/up
11	72511	Pulley Guard thru s/n 62561	62	72621	Muffler Guard
	72647	Pulley Guard s/n 62562/up	63	16211	J-Bolts, Battery Hold Down
12	72512	Motor Sled, Kohler	64	72642	Positive Cable, Red
	72672	Motor Sled, Vanguard	65	72643	Negative Cable, Black
13	72513	Discharge Clamp Half	66	16215	Hour meter/Tach, thru s/n 62549
14	72514	T-Handle, Discharge Chute		72646	Hour meter/Tach, Flush mount
15	72515	Anti Wrap Guard			s/n 62550/up
16	72516	Impeller	67	45107	Hand Grip, 3/4" Handle
17	72517	Angle Flange, Power Side	68	5001002	1/2" Lug Nut
18	72518	Angle Flange, Feed Side	69	5001225	1/2" x 1 1/2" Stud
19	72519	Bearing	70	5002516	1/2" x 2" Stud (Bearings)
20	72520	Clutch thru s/n 62581	71	3751016	Handle Nut
	72649	Clutch s/n 62582/up	72	51601	2" Ball Coupler
21	72521	Clutch Spacer thru s/n 62581	73	51602	Jack
		Only	74	72640A	Recessed Tail Light
22	72522	Clutch Retainer	75	51624	Safety Chain
23	72523	Clutch Retainer Bolt	76	51625	Safety Chain Spacer
24	72524	Pulley	77	28907	Trailer Connector
25	72525	Pulley Bushing	78	72640B	Grommet, Recessed Tail Light
26	72526	Belt	79	28839	Fuel Line Clamps
27	72527	Gas Tank, Includes Cap thru	80	72623	1/2" Romex Connector
		s/n 62581	81	72624	Fitting 90° 3/8 FP-3/8 FP
	72654	Gas Tank, Includes Cap			Kohler
		s/n 62582/up	82	72640C	Pigtail/Plug, Recessed Tail light
28	72528	Grease Fitting	83	72636	Anvil Gauge
29	72529	Safety Switch	84	72587	Guard Access Panel
30	72530	Fender Assembly	86	45061	Nylon Washer
31	72531	Engine, 25HP Kohler Elect.	87	46219	Foam Seal, Anti-Vibration
	72673	Engine, 31HP B&S Vanguard	88	16233	Gas Tank Strap s/n 62582/up
32	72532	Flywheel Safety Pin	89	16236	Male Fuel Coupler
33	72533	Trailer Frame	90	16237	Female Fuel Coupler
34	72534	Trailer Tongue	91	725338	Gas Tank Mount s/n 62582/up
35	72535	Trailer Tongue Brace, RH	92	72677	Oil Drain Tube, Vanguard
36	72536	Trailer Tongue Brace, LH	93	72680	Anti Wrap Angle
37	72537	Suspension axle w/hub	94	72681	Fender Brace
38	72538	Wheel		51650	Decal, Danger Stop Engine
42	72542	Anvil Support Spacer		51656	Decal, Caution Safety Chains
44	72544	Pulley Guard Front thru		51660	Decal, Caution Read Owner Man.
		s/n 62561		51662	Decal, Warning Flying Wood
	72648	Pulley Guard Front thru		51665	Decal, Warning Operator w/I 10ft
		s/n 62562/up		72595	Decal, Danger Feed From Side
45	72545	Gauge Cover		72596	Decal, Danger Do Not Open...
46	72646	Side Marker, Amber		72597	Decal, Warning Torque Anvil...
47	72547	Oil Drain Tube, Kohler		72598	Decal, Warning Do Not Sit-Ride
48	72548	Plug, Oil Drain, Kohler		72599	Decal, Grease Fitting
49	72549	Wire Harness, Safety Switch		51669	Decal, Powertek
50	16339	Manual Pak		162171	Float Assembly 3&6 Gal. tank
51	72551	Battery Hold Down Cap		162172	Pick-up Assembly 3&6 Gal. tank

3-12-08

PARTS BREAKDOWN (727 HYDRO PARTS)

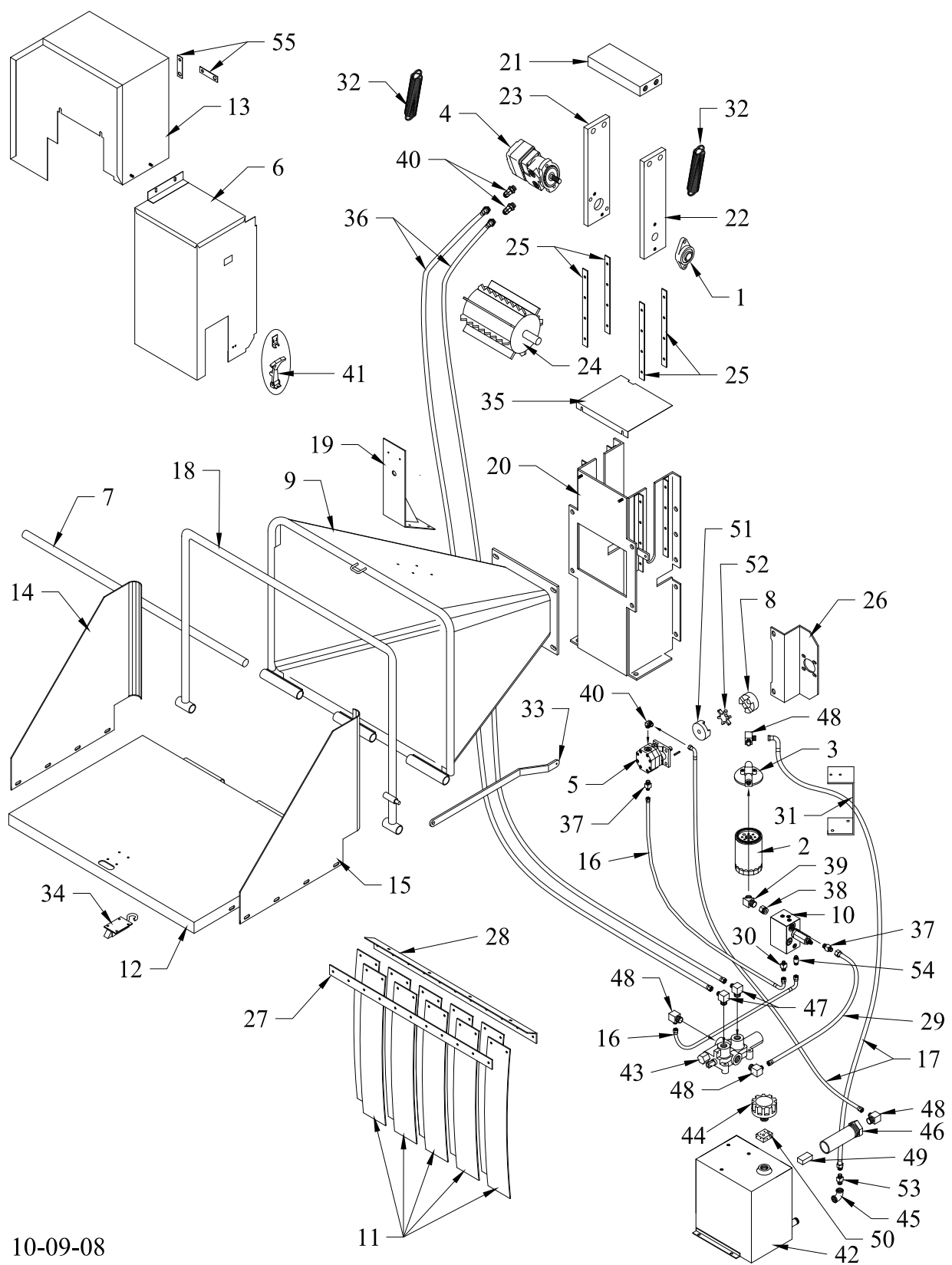

10-09-08

PARTS LIST (727 HYDRO PARTS)**POWERTEK**

<u>Key</u>	<u>Part No.</u>	<u>Description</u>	<u>Key</u>	<u>Part No.</u>	<u>Description</u>
1	72561	Flange Bearing	41	72638	Latch and Strike, Rubber Ball
2	72562	Filter Element	42	51605	Hyd. Tank
3	72563	Filter Head	43	51613	Hyd. Control Valve
4	72564	Hyd. Motor, Roller thru s/n 62818	44	51620	Hyd. Tank Breathers
	72693	Hyd. Motor, Roller s/n 62819/up	45	51621	1/2" Pipe Elbow
5	72669	Hyd. Pump, 727 Speed Ass'y	46	51630	Strainer
6	72662	Hydro Guard, 727	47	51639	Fitting-90°, 1/2" FP-1/2" MP
7	72567	Door Hinge Pin	48	51641	Fitting-90°, 1/2" MJIC-3/4" MP
8	72663	Coupling Jaw, 1 1/8"	49	51643	Magnet
9	72569	Hyd. Feed Chute	50	51677	Cap Foam
10	72658	Priority Control Ass'y	51	82512B	Coupling Jaw 1/2"
11	72571	Rubber Flap	52	72695	Spider Coupling, Urethane
12	72572	Chute Door	53	72616	Fitting, 1/2" MJIC-1/2" MP
13	72661	Guard Box Ass'y	54	72670	Check Valve, Priority Control
14	72574	L.H. Chute Guide	55	72682	Mount Tab, Guard
15	72575	R.H. Chute Guide			
16	72664	Hose, 3/4 FJIC-3/4 FJIC w/90°x 18"			
17	72665	Hose, 3/4 FJIC-3/4 FJIC w/90°x 28"			
18	72578	Chute, Lever Ass'y			
19	72579	Mount, Stop Switch			
20	72580	Hyd. Feed Housing			
21	72581	Stabilizer Plate			
22	72582	R.H. Bearing Guide			
23	72583	L.H. Bearing Guide			
24	72584	Roller, Hyd. Feed thru s/n 62818			
	72692	Roller, Hyd. Feed s/n 62819/up			
25	72585	U.H.M.W. Roller Guide			
26	72666	Pump Mount Bracket			
27	72588	Guard Strip			
28	72589	Guard Bracket			
29	72667	Hose, 3/4 FJIC-3/4 FJIC x 16"			
30	72668	Fitting, 9/16 O-ring to 3/4 MJIC			
31	72592	Filter Mount			
32	72594	Spring, Roller Guide			
33	72601	Activator Lever			
34	72605	Door Latch			
35	72608	Chamber Cover			
36	72611	Hose, 1/2" FJIC-1/2" FJIC x 48"			
37	72613	Fitting, 1/2" MJIC-3/4" o-ring			
38	72614	Fitting, 1/2" FJIC-3/4" o-ring			
39	72615	Fitting-45°, 1/2" MJIC-3/4" MP			
40	72617	Fitting-90°, 1/2" MJIC-7/8" o-ring			

2-20-08

Additional or replacement manuals may be obtained from your local PowerTek distributor. When chipper is received, complete the following record.

SERIAL NUMBER: _____

DATE OF PURCHASE: _____

WHERE PURCHASED: _____

Always mention the machine's model and serial number when ordering or writing about parts.

For convenience in ordering, parts are listed by part number, description and quantity. Always supply part number and complete description when ordering. When assemblies can be used, order them to save time assembling individual parts. Prior arrangements must be made before returning chipper for warranty service. Service calls should be directed to Customer Service at 1-877-769-7835.

To insure correct and prompt shipment of parts, always provide the following information when ordering.

1. Quantity of each part wanted
2. Part number and description
3. Model and serial number of chipper
4. Preferred method of shipment: by mail, UPS, or airfreight

WARRANTY INFORMATION

Each new product is warranted against manufacturing defects in workmanship and/or materials under normal use and service for a period of 12 months from the date of delivery of the product to the original purchaser. PowerTek Inc.'s obligation under this warranty shall be limited to the replacement to the original purchaser of any part which, as delivered to the original purchase, and upon PowerTek Inc.'s examination, is shown to PowerTek Inc.'s satisfaction, to be defective due to faulty workmanship or materials at the factory.

This warranty does not apply to damage in transit, damage caused by user misuse, negligence, accident, normal wear, or alterations or repairs done outside the factory and/or authorized service stations as determined by PowerTek Inc.

All parts claimed to be defective must be returned to PowerTek Inc.'s factory for inspection, repair or replacement, with all transportation or mailing charges prepaid. It is the exclusive responsibility of the purchaser to bear the transportation or mailing charges on any warranty claim.

This warranty specifically excludes engines or batteries, which are warranted separately by their respective manufacturers, all claims for defective batteries, engines or engine parts must be made in accordance with the battery and /or engine manufacturer's warranty. This warranty also specifically excludes costs of regular maintenance and replacement of service items such as belts, hoses, blades, and similar items.

PowerTek Inc. reserves the right to make changes upon PowerTek Inc.'s products without imposing any obligation upon PowerTek Inc. to install the same on a product manufactured prior to the change.

PowerTek Inc. makes no other warranties, representations or promises other than those set forth herein. **PowerTek Inc. specifically disclaims any and all implied warranties of fitness for particular purpose and merchantability.**

The remedies available to a distributor, dealer, and/or purchaser in connection with PowerTek Inc.'s warranty are set forth above. In no event will PowerTek Inc. be liable for special, incidental or consequential damages.

POWERTEK INC. WARRANTY PROCEDURE

- A. All requests for warranty must have approval from PowerTek Inc. and/or distributor before work starts, or the warranty claim will be denied.
- B. All requests for warranty must be made on an OPEI or equivalent warranty claim form. This form is available from PowerTek Inc. or an authorized PowerTek Inc. distributor or dealer on a no charge basis.
- C. It is the responsibility of the distributor or dealer to complete the form warranty claim and submit it to PowerTek Inc..
 1. The form must be filled out completely. Claims received without serial numbers, model numbers, replacement part numbers, purchase dates, repair dates, purchaser's correct address, signature or other information requested by PowerTek Inc. shall be denied.
 2. Warranty claims that are illegible will be returned without service. Please type or print in black ink.
 3. PowerTek Inc.'s warranty makes no allowance for the time spent to fill out the warranty claim. Any such claim will be denied.

WARRANTY PROCEDURE (CONTINUED)

4. All parts shall be retained and tagged for a period of 60 days or until credit is issued.
 5. The factory may request parts to be returned for examination or analysis. These parts shall be sent by prepaid freight to PowerTek Inc. Returns sent freight collect, without express, written permission from PowerTek Inc. shall not be accepted.
 6. It is the responsibility of the dealer to review the claim and to comply fully with all procedures set forth herein. Failure to do so shall result in the denial of the warranty claim.
- D. Any warranty payments by PowerTek Inc. will be paid by credit memo to the distributor, dealer.
- E. All warranty claims, which are denied, will be returned with a reason for denial.
- F. Labor Allowance.
1. The warranty labor rate is \$35.00 per hour.
 2. The actual time is divided into tenths of an hour. The warranty form should show the time to the nearest tenth of an hour.
 3. Labor credit is based on the actual time required only to make the repair.
- G. Items not covered by warranty.
1. Mileage and transportation costs of any kind. All warranty is "Bench Work" only. The warranty specifically states that any transportation charges in connection with a warranty repair is the exclusive responsibility of the purchaser.
 2. Postage, delivery, telephone calls or similar communications.
 3. Normal maintenance or adjustments. This includes set up and service.
 4. Battery, engine or engine parts. Warranty on batteries, engines, engine parts or other vendor parts is covered by the component manufacturer's warranty and must be handled by that component manufacturer's representative.
 5. Failure caused by neglect, normal wear, or abuse. PowerTek Inc. depends on its distributor and dealer network to accurately determine when such conditions occur.
 6. Any alteration of the original design of the unit or the use of unauthorized or non-PowerTek Inc. parts. Any claim submitted containing such unauthorized alteration repairs shall be rejected.
 7. Freight or transportation damage. All such damage is the responsibility of the carrier and any claim for damages must be made with the carrier.
 8. Compound or repeat warranties caused by negligent/improper repair.
 9. Any claim for warranty where the date of repair exceeds sixty (60) days from the submission of the warranty claim.
 10. Any claim for warranty on the entire unit.
 11. Warranty claims involving oils or fluids of any kind.
 12. Any warranty claims for leaking, punctured, blown, flat, or otherwise damaged tires on units that have been placed in service.
 13. Lost time, lost rentals, lost profits, or other economic loss due to warranty work.

Voluntary cooperation with the entire warranty procedure will make the program work better for both the purchaser and PowerTek Inc.